



NTA

Nutek Advanced Series

PCB handling



Company

Nutek Europe BV is the European distributor of Nutek Board Handling & Traceability Equipment and is the leading supplier of this equipment for the European, African and Middle East PCB Assembly industry.

Our history traces back to 1992, when Nutek Europe obtained the exclusive European sales rights of Nutek Pte Ltd, Singapore. Since then a network of agents has been setup and maintained to serve customers throughout our sales region. The agents are supported by the Nutek Europe's area sales managers who are familiar with the entire production process and specialize in several specific areas.

Nutek Europe has its own customer-service department with a fast response time. Naturally, Nutek Europe has the necessary spare parts on stock for fast delivery, if required.

The Nutek Europe facility offers adequate space for customer demonstrations, technical- and sales training and has a 750 square meter warehouse, where the European stock of Nutek equipment, including spare parts and magazine racks are stored.

Contents

Magazine Line loaders & magazine line unloaders

- Single magazine line loader.
- Single magazine line unloader.
- Dual magazine line loader.
- Dual magazine line unloader.
- Dual magazine line loader (Stationary platform).
- Dual magazine line unloader (Stationary platform).
- Triple magazine line loader.
- Triple magazine line unloader.
- Triple magazine line loader (Stationary platform).
- Triple magazine line unloader (Stationary platform).
- Multi magazine line loader.
- Multi magazine line unloader.
- Multi magazine line loader (Stationary platform).
- Multi magazine line unloader (Stationary platform).
- Multi magazine line loader (L-Type).
- Multi magazine line unloader (L-Type).
- Pusher conveyor.

Traffic controllers

- Inverter.
- Lifter.
- Turn conveyor (L, T, I, X type).
- Shuttle conveyor.

Nutek Advanced series summary

In the everchanging PCB fabrication industry there is a need to be as versatile as possible, high flexibility and production cost reduction are important topics.

With the use of servo motors, automatic product change-over, the line control software preparation, a large database of product recipes, multiple machine to machine communication options (e.g. IPC-HERMES-9852) this range is ideal for fast and easy product change-over.

The operator is not forgotten by means of an intuitive graphic touch screen display, that allows easy operation and high flexibility.

Nutek is known for its high quality, highly customizable board handling since 1989 and with the NTA series ready for the future and industry 4.0.

Bare board loaders & Bare board unloaders

- Bareboard loader (by-pass).
- Destacker.
- Push-up destacker.
- Push-up stacker.

Conveyors

- Linking conveyor.
- Inspection conveyor.
- Reject conveyor.
- Inline workstation.
- Manual gate.
- Telescopic gate.
- Telescopic gate NC/NO.
- PCB cleaning conveyor.

Buffers

- Single magazine buffer.
- Multi magazine buffer.
- FIFO buffer.
- Belt FIFO buffer.

NTA 710LM • NTA 710LXL

The NTA 710L is a single magazine line loader with a servo driven magazine lifter platform with a single magazine capacity.

The magazine is manually placed and clamped on the platform. The pneumatic pusher is used to push a PCB out of the magazine to the downstream machine.

The 7" full colour touchscreen display allows easy operation on multiple user levels.



7" full colour touchscreen display.

Standard features

- Servo driven lifter platform.
- 7" full colour touchscreen display.
- Advanced graphic Human Machine Interface (HMI).
- Multi level user access control.
- In,- & Output diagnostics on touchscreen display.
- Flexible pitch settings.
- 2000 product recipes storage.
- 10 magazine recipes storage.
- Magazine unloading selectable 'top to bottom' or 'bottom to top'.
- Regulated pressure on the pusher cylinder.
- Manually adjustable pusher position.
- Ethernet connection for network interface.
- Towerlight display for machine status.

Options

- IPC-HERMES-9852 communication.
- Automatic product change-over by Nutek leader - follower software.
- Line Control Software ready.
- Automatic pusher positioning.
- Remotely accessible PLC.
- Cantilevered output conveyor (500 mm).
- Remotely accessible PLC.
- Front side magazine loading.
- Alarm buzzer.

Other options available on request.



NTA 710LM • NTA 710LXL

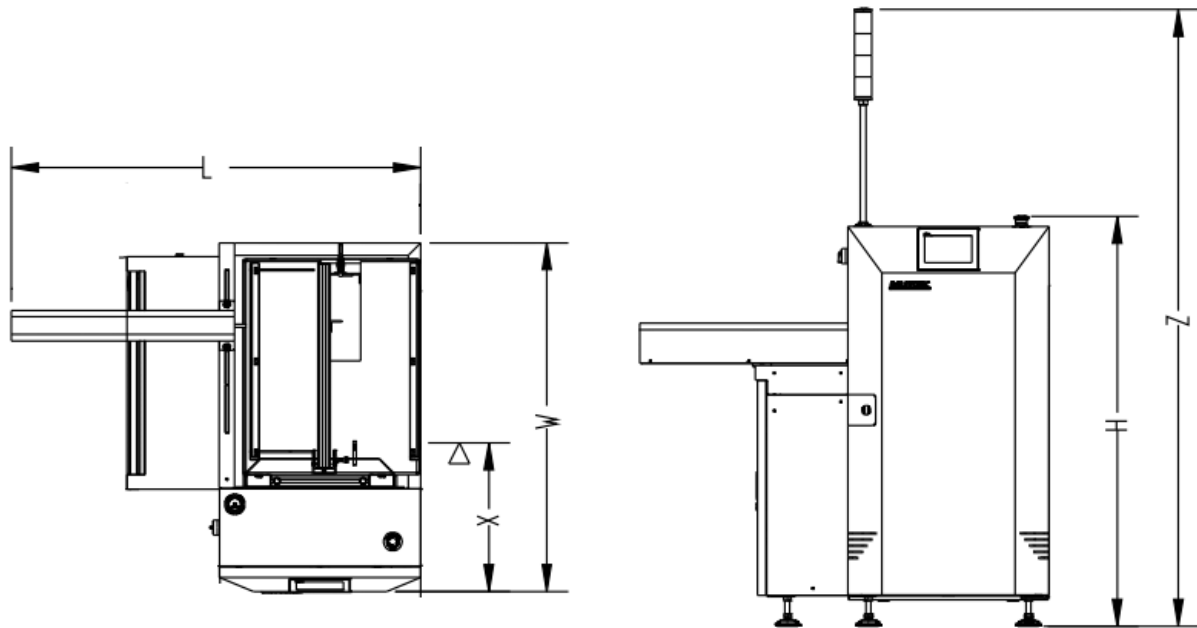

General machine specification

Transfer height:	950 mm ± 25 mm*
Colour:	RAL 9002*
Flow direction:	Left to right*
Fixed rail:	Front*
Machine interface:	IPC-SMEMA-9851*
Components clearance:	Top 30 mm, bottom 30 mm*
PCB loading time:	± 7 seconds
Pitch control:	Flexible pitch settings
Maximum total magazine weight:	50 kg

Installation requirements

Power supply:	230 VAC/50 Hz/1 Ph
Power consumption:	410 VA max
Air supply:	6 bar
Air consumption:	10 ltr/min max

Machine dimensions	NTA 710LM	NTA 710LXL
Machine dimensions (l x w x h):	1265 x 880 x 1330 mm	1330 x 1130 x 1330 mm
Machine weight:	170 kg	180 kg
Fixed rail to front dimension (X):	475 mm	475 mm
Towerlight height (Z):	2000 mm	2000 mm

PCB dimensions	NTA 710LM	NTA 710LXL
PCB length:	80 - 330 mm	80 - 460 mm*
PCB width:	50 - 250 mm	50 - 460 mm*
PCB thickness:	0,4 - 2,6 mm*	0,4 - 2,6 mm*
PCB weight:	2,5 kg*	2,5 kg*
Magazine dimensions (max.):	355 x 320 x 570 mm*	535 x 530 x 570 mm*

* Depending on specification.



NTA 710UM • NTA 710UXL

The NTA 710U is a single magazine line unloader with a servo driven magazine lifter platform with a single magazine capacity. The magazine is manually placed and clamped on the platform. The cantilevered pusher conveyor is used to collect a PCB from the upstream machine and push it into the magazine. The 7" full colour touchscreen display allows easy operation on multiple user levels.



7" full colour touchscreen display.

Standard features

- Servo driven lifter platform.
- Automatic conveyor width adjustment.
- 7" full colour touchscreen display.
- Advanced graphic Human Machine Interface (HMI),
- Multi level user access control,
- In,- & Output diagnostics on touchscreen display.
- Flexible pitch settings.
- 2000 product recipes storage.
- 10 magazine recipes storage.
- Selectable 'top to bottom' or 'bottom to top' sequence.
- Regulated pressure on the pusher cylinder.
- Manually adjustable pusher position.
- Ethernet connection.
- Towerlight display for machine status.

Options

- IPC-HERMES-9852 communication.
- Automatic product change-over by Nutek leader - follower software.
- Line Control Software ready.
- Automatic pusher positioning.
- Pusher position moves in ratio 1:2 with conveyor width.
- Remotely accessible PLC.
- Front side magazine loading.
- Pneumatic stopper, to control PCB flow from upstream reflow oven.
- Alarm buzzer.

Other options available on request



NTA 710UM • NTA 710UXL

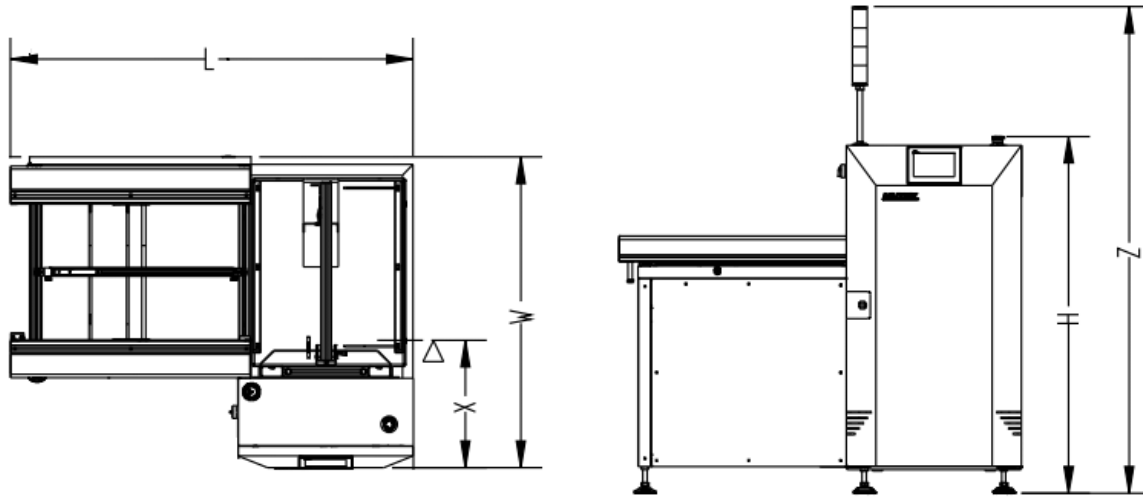

General machine specification

Transfer height:	950 mm ± 25 mm*
Colour:	RAL 9002*
Flow direction:	Left to right*
Fixed rail:	Front*
Machine interface:	IPC-SMEMA-9851*
Components clearance:	Top 30 mm, bottom 30 mm*
Belt speed:	14 m/min
PCB edge support:	3 mm
PCB loading time:	± 6 seconds
Pitch control:	Flexible pitch settings
Maximum magazine weight:	50 kg (each)

Installation requirements

Power supply:	230 VAC/50 Hz/1 Ph
Power consumption:	530 VA max.
Air supply:	6 bar
Air consumption:	10 ltr/min max.

Machine dimensions

	NTA 710UM	NTA 710UXL
Machine dimensions (l x w x h):	1200 x 900 x 1330 mm	1500 x 1160 x 1330 mm
Machine weight:	200 kg	230 kg
Fixed rail to front dimension (X):	475 mm	475 mm
Towerlight height (Z):	2000 mm	2000 mm

PCB dimensions

	NTA 710UM	NTA 710UXL
PCB length:	80 - 330 mm	80 - 460 mm*
PCB width:	50 - 250 mm	50 - 460 mm*
PCB thickness:	0,4 - 2,6 mm*	0,4 - 2,6 mm*
PCB weight:	2,5 kg*	2,5 kg*
Magazine dimensions (max.):	355 x 320 x 570 mm	535 x 530 x 570 mm

* Depending on specification.



NTA 720LM • NTA 720LXL

The NTA 720L is a dual magazine line loader with a servo driven magazine lifter platform with two magazines placed side by side. The magazines are manually placed and clamped on the platform. The servo driven shuttle conveyor moves sideways between the magazines. A puller cylinder extracts a PCB from the magazine onto the shuttle conveyor. An empty magazine can be exchanged at any time. The 7" full colour touchscreen display allows easy operation on multiple user levels.



Rotating puller tip (optional).



7" full colour touchscreen display.

Standard features

- Servo driven lifter platform.
- Servo driven shuttle conveyor movement.
- Automatic conveyor width adjustment.
- 7" full colour touchscreen display.
- Advanced graphic Human Machine Interface (HMI).
- Multi level user access control.
- In,- & Output diagnostics on touchscreen display.
- Flexible pitch settings.
- 2000 product recipes storage.
- 10 magazine recipes storage.
- Magazine unloading 'top to bottom'.
- Top 5 magazine slots to remain empty.
- Regulated pressure on the puller cylinder.
- Manually adjustable puller position.
- Ethernet connection for network interface.
- Towerlight display for machine status.

Options

- IPC-HERMES-9852 communication.
- Automatic product change-over by Nutek leader - follower software.
- Line Control Software ready.
- Automatic puller positioning.
- Puller position moves in ratio 1:2 with conveyor width.
- Magazine unloading 'bottom to top'.
- Remotely accessible PLC.
- Safety shutter at outlet.
- Rotating puller tip.
- Alarm buzzer.

Other options available on request.

NTA 720LM • NTA 720LXL

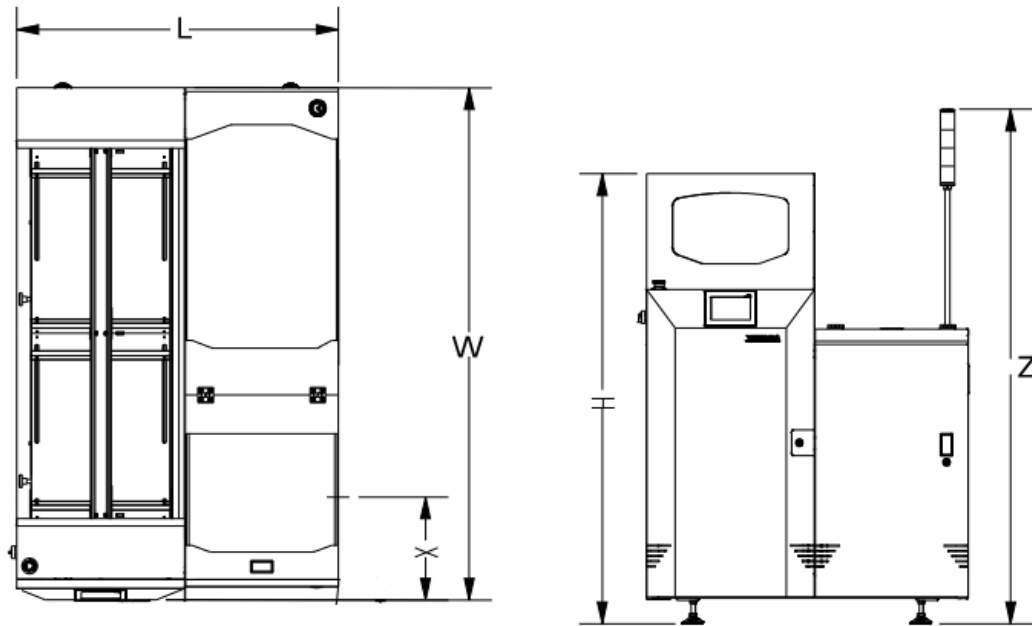

General machine specification

Transfer height:	950 mm ± 25 mm*
Colour:	RAL 9002*
Flow direction:	Left to right*
Fixed rail:	Front*
Machine interface:	IPC-SMEMA-9851*
Components clearance:	Top 30 mm, bottom 30 mm*
Belt speed:	14 m/min
PCB edge support:	3 mm
PCB loading time:	± 18 seconds (rear magazine)
Pitch control:	Flexible pitch settings
Maximum magazine weight:	50 kg (each)

Installation requirements

Power supply:	230 VAC/50 Hz/1 Ph
Power consumption:	830 VA max.
Air supply:	6 bar
Air consumption:	10 ltr/min max.

Machine dimensions	NTA 720LM	NTA 720LXL
Machine dimensions (l x w x h):	1080 x 1370 x 1750 mm	1250 x 1990 x 1750 mm
Machine weight:	330 kg	480 kg
Fixed rail to front dimension (X):	400 mm	400 mm
Towerlight height (Z):	2000 mm	2000 mm

PCB dimensions	NTA 720LM	NTA 720LXL
PCB length:	80 - 330 mm	80 - 460 mm*
PCB width:	50 - 250 mm	50 - 460 mm*
PCB thickness:	0,4 - 2,6 mm*	0,4 - 2,6 mm*
PCB weight:	2,5 kg*	2,5 kg*
Magazine dimensions (max.):	355 x 320 x 570 mm	535 x 530 x 570 mm

* Depending on specification.



NTA 720UM • NTA 720UXL

The NTA 720U is a dual magazine line unloader with a servo driven magazine lifter platform with two magazines placed side by side. The magazines are manually placed and clamped on the platform. The servo driven shuttle conveyor moves sideways between the magazines. A cylinder on the shuttle conveyor is used to push a PCB completely in the magazine .

An empty magazine can be exchanged at any time.

The 7" full colour touchscreen display allows easy operation on multiple user levels.



Servo driven shuttle conveyor.



7" full colour touchscreen display.

Standard features

- Servo driven lifter platform.
- Servo driven shuttle conveyor movement.
- Automatic conveyor width adjustment.
- 7" full colour touchscreen display.
- Advanced graphic Human Machine Interface (HMI).
- Multi level user access control.
- In,- & Output diagnostics on touchscreen display.
- Flexible pitch settings.
- 2000 product recipes storage.
- 10 magazine recipes storage.
- Magazine loading 'top to bottom'.
- Regulated pressure on the pusher cylinder.
- Manually adjustable pusher position.
- Oven info threshold signal.
- Good/bad separation function.
- Ethernet connection for network interface.
- Towerlight display for machine status.

Options

- IPC-HERMES-9852 communication.
- Automatic product change-over by Nutek leader - follower software.
- Line Control Software ready.
- Automatic pusher positioning.
- Pusher position moves in ratio 1:2 with conveyor width.
- Remotely accessible PLC.
- Safety shutter at inlet.
- Pneumatic stopper, to control PCB flow from upstream reflow oven.
- Intelligent threshold counter to stop PCB infeed into reflow oven.
- Alarm buzzer.

Other options available on request.

NTA 720UM • NTA 720UXL

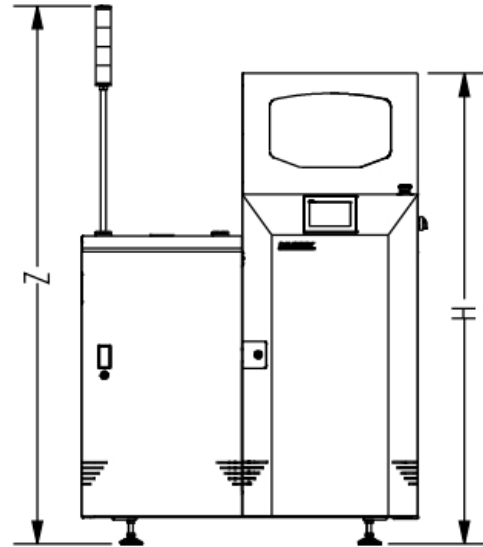
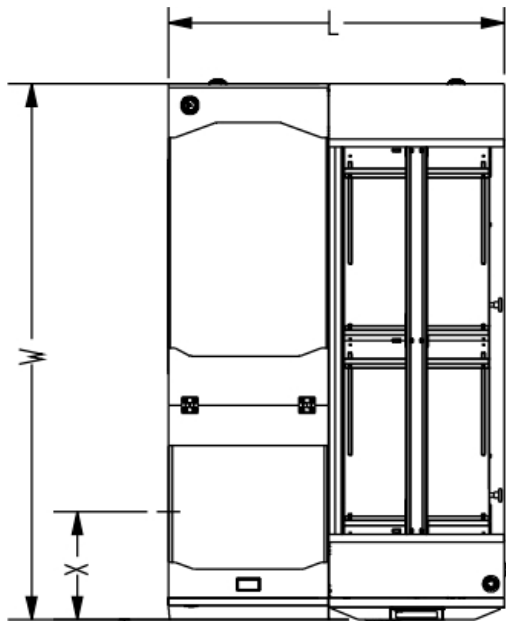

General machine specification

Transfer height:	950 mm ± 25 mm*
Colour:	RAL 9002*
Flow direction:	Left to right*
Fixed rail:	Front*
Machine interface:	IPC-SMEMA-9851*
Components clearance:	Top 30 mm, bottom 30 mm*
Belt speed:	14 m/min
PCB edge support:	3 mm
PCB unloading time:	± 15 seconds (rear magazine board to board)
Pitch control:	Flexible pitch settings
Maximum magazine weight:	50 kg (each)

Installation requirements

Power supply:	230 VAC/50 Hz/1 Ph
Power consumption:	830 VA max.
Air supply:	6 bar
Air consumption:	5 ltr/min max.

Machine dimensions

	NTA 720UM	NTA 720UXL
Machine dimensions (l x w x h):	1080 x 1370 x 1750 mm	1250 x 1990 x 1750 mm
Machine weight:	330 kg	480 kg
Fixed rail to front dimension (X):	400 mm	400 mm
Towerlight height (Z):	2000 mm	2000 mm

PCB dimensions

	NTA 720UM	NTA 720UXL
PCB length:	80 - 330 mm	80 - 460 mm*
PCB width:	50 - 250 mm	50 - 460 mm*
PCB thickness:	0,4 - 2,6 mm*	0,4 - 2,6 mm*
PCB weight:	2,5 kg*	2,5 kg*
Magazine dimensions (max.):	355 x 320 x 570 mm	535 x 530 x 570 mm

* Depending on specification.

NTA 72ILM • NTA 72ILXL

The NTA 721L is a dual magazine line loader with a stationary magazine platform with two magazines placed side by side. The magazines are manually placed and clamped on the platform. The servo driven shuttle conveyor moves in horizontal and vertical direction to align with the magazine and slot position. A puller cylinder extracts a PCB from the magazine onto the shuttle conveyor. An empty magazine can be exchanged at any time. The 7" full colour touchscreen display allows easy operation on multiple user levels.



Magazine conveyor.



Rotating puller tip (optional).



7" full colour touchscreen display.

Standard features

- Stationary magazine platform prepared for loading with AGV/AIV.
- Servo driven shuttle conveyor movement (vertical & horizontal).
- Automatic conveyor width adjustment.
- 7" full colour touchscreen display.
- Advanced graphic Human Machine Interface (HMI).
- Multi level user access control.
- In,- & Output diagnostics on touchscreen display.
- Flexible pitch settings.
- 2000 product recipes storage.
- 10 magazine recipes storage.
- Magazine unloading 'top to bottom'.
- Top 5 magazine slots to remain empty.
- Regulated pressure on the puller cylinder.
- Manually adjustable puller position.
- Ethernet connection for network interface.
- Towerlight display for machine status.

Options

- IPC-HERMES-9852 communication.
- Automatic product change-over by Nutek leader - follower software.
- Line Control Software ready.
- Automatic puller positioning.
- Puller position moves in ratio 1:2 with conveyor width.
- Magazine unloading 'bottom to top'.
- Remotely accessible PLC.
- Safety shutter at outlet.
- Rotating puller tip.
- Alarm buzzer.

Other options available on request.

NTA 721LM • NTA 721LXL

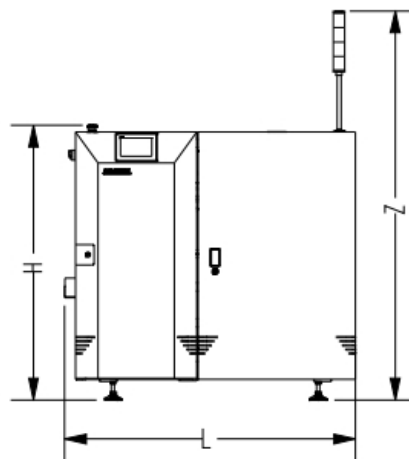
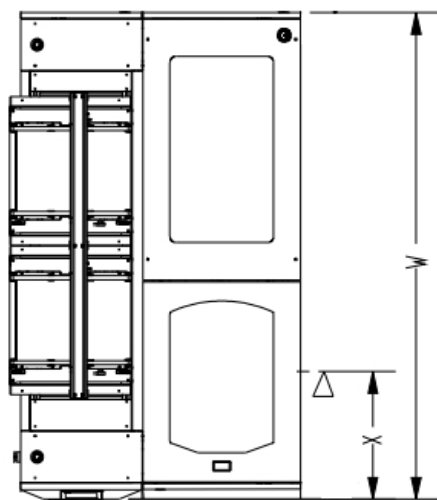

General machine specification

Transfer height:	950 mm ± 25 mm*
Colour:	RAL 9002*
Flow direction:	Left to right*
Fixed rail:	Front*
Machine interface:	IPC-SMEMA-9851*
Components clearance:	Top 30 mm, bottom 30 mm*
Belt speed:	14 m/min
PCB edge support:	3 mm
PCB loading time:	± 18 seconds (rear magazine)
Pitch control:	Flexible pitch settings
Maximum magazine weight:	50 kg (each)

Installation requirements

Power supply:	230 VAC/50 Hz/1 Ph
Power consumption:	830 VA max.
Air supply:	6 bar
Air consumption:	10 ltr/min max.

Machine dimensions

	NTA 721LM	NTA 721LXL
Machine dimensions (l x w x h):	1420 x 1730 x 1330 mm	1420 x 2365 x 1330 mm
Machine weight:	330 kg	480 kg
Fixed rail to front dimension (X):	535 mm	535 mm
Towerlight height (Z):	2000 mm	2000 mm

PCB dimensions

	NTA 721LM	NTA 721LXL
PCB length:	80 - 330 mm	80 - 460 mm*
PCB width:	50 - 250 mm	50 - 460 mm*
PCB thickness:	0,4 - 2,6 mm*	0,4 - 2,6 mm*
PCB weight:	2,5 kg*	2,5 kg*
Magazine dimensions (max.):	355 x 320 x 570 mm	535 x 530 x 570 mm

* Depending on specification.

NTA 72IUM • NTA 72IUXL

The NTA 721U is a dual magazine line unloader with a stationary magazine platform with two magazines placed side by side. The magazines are manually placed and clamped on the platform. The servo driven shuttle conveyor moves in horizontal and vertical direction to align with the magazine and slot position. A cylinder on the shuttle conveyor is used to push a PCB completely in the magazine. An empty magazine can be exchanged at any time. The 7" full colour touchscreen display allows easy operation on multiple user levels.



Magazine conveyor..



Servo driven shuttle conveyor.



7" full colour touchscreen display.

Standard features

- Stationary magazine platform prepared for loading with AGV/AIV.
- Servo driven shuttle conveyor movement (vertical & horizontal).
- Automatic conveyor width adjustment.
- 7" full colour touchscreen display.
- Advanced graphic Human Machine Interface (HMI).
- Multi level user acces control.
- In,- & Output diagnostics on touchscreen display.
- Flexible pitch settings.
- 2000 product recipes storage.
- 10 magazine recipes storage.
- Magazine loading 'top to bottom'.
- Regulated pressure on the pusher cylinder.
- Manually adjustable pusher position.
- Oven info treshold signal.
- Good/bad separation function.
- Ethernet communication for network interface.
- Towerlight display for machine status.

Options

- IPC-HERMES-9852 communication.
- Automatic product change-over by Nutek leader - follower software.
- Line Control Software ready.
- Automatic pusher positioning.
- Pusher position moves in ratio 1:2 with conveyor width.
- Remotely accessible PLC.
- Safety shutter at inlet.
- Pneumatic stopper, to control PCB flow from upstream reflow oven.
- Intelligent treshold counter to stop PCB infeed into reflow oven.
- Alarm buzzer.

Other options available on request.



NTA 72IUM • NTA 72IUXL

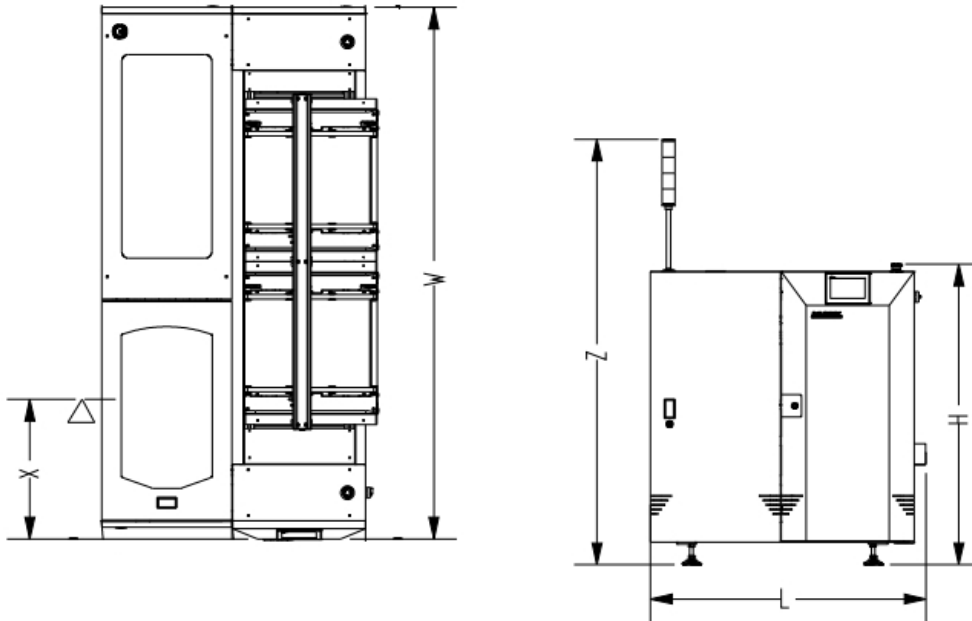

General machine specification

Transfer height:	950 mm ± 25 mm*
Colour:	RAL 9002*
Flow direction:	Left to right*
Fixed rail:	Front*
Machine interface:	IPC-SMEMA-9851*
Components clearance:	Top 30 mm, bottom 30 mm*
Belt speed:	14 m/min
PCB edge support:	3 mm
PCB unloading time:	± 15 seconds (rear magazine board to board)
Pitch control:	Flexible pitch settings
Maximum magazine weight:	50 kg (each)

Installation requirements

Power supply:	230 VAC/50 Hz/1 Ph
Power consumption:	830 VA max.
Air supply:	6 bar
Air consumption:	10 ltr/min max.

Machine dimensions

	NTA 72IUM	NTA 72IUXL
Machine dimensions (l x w x h):	1420 x 1730 x 1330 mm	1420 x 2365 x 1330 mm
Machine weight:	330 kg	480 kg
Fixed rail to front dimension (X):	535 mm	535 mm
Towerlight height (Z):	2000 mm	2000 mm

PCB dimensions

	NTA 72IUM	NTA 72IUXL
PCB length:	80 - 330 mm	80 - 460 mm*
PCB width:	50 - 250 mm	50 - 460 mm*
PCB thickness:	0,4 - 2,6 mm*	0,4 - 2,6 mm*
PCB weight:	2,5 kg*	2,5 kg*
Magazine dimensions (max.):	355 x 320 x 570 mm	535 x 530 x 570 mm

* Depending on specification.

NTA 730LM • NTA 730LXL

The NTA 730L is a triple magazine line loader with a servo driven magazine lifter platform with three magazines placed side by side. The magazines are manually placed and clamped on the platform. The servo driven shuttle conveyor moves sideways between the magazines. A puller cylinder extracts a PCB from the magazine onto the shuttle conveyor. An empty magazine can be exchanged at any time. The 7" full colour touchscreen display allows easy operation on multiple user levels.



Rotating puller tip (optional).



7" full colour touchscreen display.

Standard features

- Servo driven lifter platform.
- Servo driven shuttle conveyor movement.
- Automatic conveyor width adjustment.
- 7" full colour touchscreen display.
- Advanced graphic Human Machine Interface (HMI).
- Multi level user access control.
- In,- & Output diagnostics on touchscreen display.
- Flexible pitch settings.
- 2000 product recipes storage.
- 10 magazine recipes storage.
- Magazine unloading 'top to bottom'.
- Top 5 magazine slots to remain empty.
- Regulated pressure on the puller cylinder.
- Manually adjustable puller position.
- Ethernet connection for network interface.
- Towerlight display for machine status.

Options

- IPC-HERMES-9852 communication.
- Automatic product change-over by Nutek leader - follower software.
- Line Control Software ready.
- Automatic puller positioning.
- Puller position moves in ratio 1:2 with conveyor width.
- Magazine unloading 'bottom to top'.
- Remotely accessible PLC.
- Safety shutter at outlet.
- Rotating puller tip.
- Alarm buzzer.

Other options available on request.

NTA 730LM • NTA 730LXL

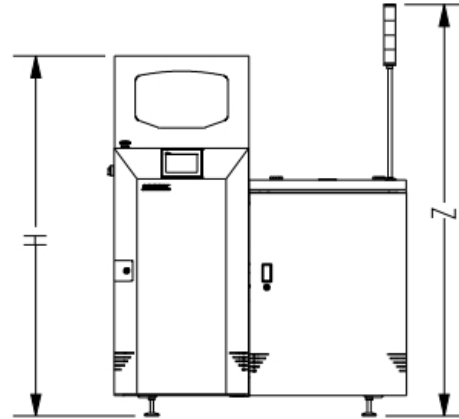
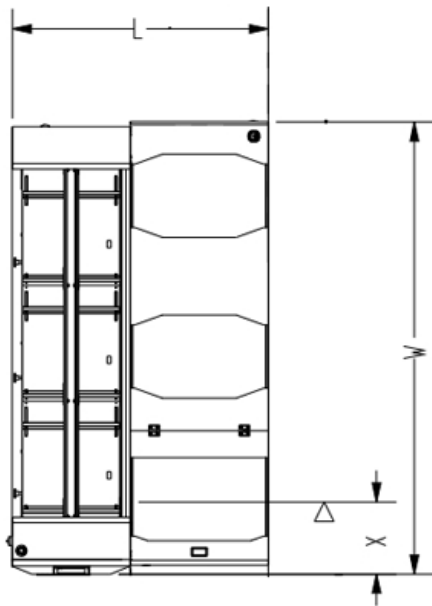

General machine specification

Transfer height:	950 mm ± 25 mm*
Colour:	RAL 9002*
Flow direction:	Left to right*
Fixed rail:	Front*
Machine interface:	IPC-SMEMA-9851*
Components clearance:	Top 30 mm, bottom 30 mm*
Belt speed:	14 m/min
PCB edge support:	3 mm
PCB loading time:	± 18 seconds (rear magazine)
Pitch control:	Flexible pitch settings
Maximum magazine weight:	50 kg (each)

Installation requirements

Power supply:	230 VAC/50 Hz/1 Ph
Power consumption:	930 VA max.
Air supply:	6 bar
Air consumption:	10 ltr/min max.

Machine dimensions

	NTA 730LM	NTA 730LXL
Machine dimensions (l x w x h):	1080 x 1805 x 1750 mm	1420 x 2505 x 1750 mm
Machine weight:	430 kg	580 kg
Fixed rail to front dimension (X):	400 mm	400 mm
Towerlight height (Z):	2000 mm	2000 mm

PCB dimensions

	NTA 730LM	NTA 730LXL
PCB length:	80 - 330 mm	80 - 460 mm*
PCB width:	50 - 250 mm	50 - 460 mm*
PCB thickness:	0,4 - 2,6 mm*	0,4 - 2,6 mm*
PCB weight:	2,5 kg*	2,5 kg*
Magazine dimensions (max.):	355 x 320 x 570 mm	535 x 530 x 570 mm

* Depending on specification:



NTA 730UM • NTA 730UXL

The NTA 730U is a triple magazine line unloader with a servo driven magazine lifter platform with three magazines placed side by side. The magazines are manually placed and clamped on the platform. The servo driven shuttle conveyor moves sideways between the magazines. A cylinder on the shuttle conveyor is used to push a PCB completely in the magazine. An empty magazine can be exchanged at any time. The 7" full colour touchscreen display allows easy operation on multiple user levels.



Servo driven shuttle conveyor.



7" full colour touchscreen display.

Standard features

- Servo driven lifter platform.
- Servo driven shuttle conveyor movement.
- Automatic conveyor width adjustment.
- 7" full colour touchscreen display.
- Advanced graphic Human Machine Interface (HMI).
- Multi level user access control.
- In-, & Output diagnostics on touchscreen display.
- Flexible pitch settings.
- 2000 product recipes storage.
- 10 magazine recipes storage.
- Magazine loading 'top to bottom'.
- Regulated pressure on the pusher cylinder.
- Manually adjustable pusher position.
- Oven info threshold signal.
- Good/bad separation function.
- Ethernet connection for network interface.
- Towerlight display for machine status.

Options

- IPC-HERMES-9852 communication.
- Automatic product change-over by Nutek leader - follower software.
- Line Control Software ready.
- Automatic pusher positioning.
- Pusher position moves in ratio 1:2 with conveyor width.
- Remotely accessible PLC.
- Safety shutter at inlet.
- Pneumatic stopper, to control PCB flow from upstream reflow oven.
- Intelligent threshold counter to stop PCB infeed into reflow oven.
- Alarm buzzer.

Other options available on request.

NTA 730UM • NTA 730UXL

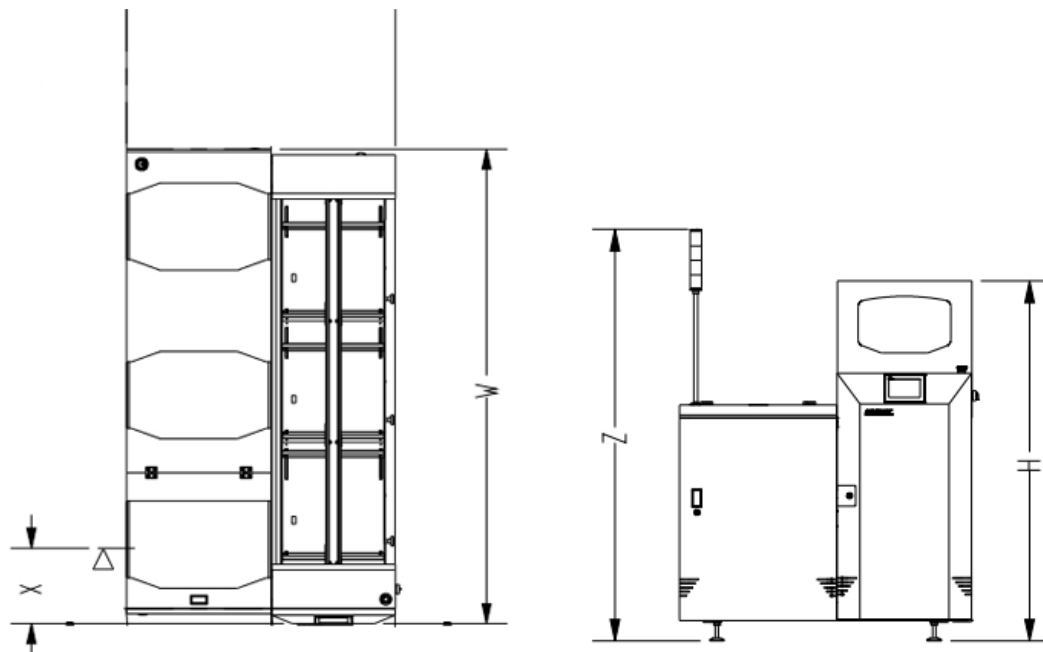

General machine specification

Transfer height:	950 mm ± 25 mm*
Colour:	RAL 9002*
Flow direction:	Left to right*
Fixed rail:	Front*
Machine interface:	IPC-SMEMA-9851*
Components clearance:	Top 30 mm, bottom 30 mm*
Belt speed:	14 m/min
PCB edge support:	3 mm
PCB unloading time:	± 18 seconds
Pitch control:	Flexible pitch settings
Maximum magazine weight:	50 kg (each)

Installation requirements

Power supply:	230 VAC/50 Hz/1 Ph
Power consumption:	930 VA max.
Air supply:	6 bar
Air consumption:	5 ltr/min max.

Machine dimensions

	NTA 730UM	NTA 730UXL
Machine dimensions (l x w x h):	1080 x 1805 x 1750 mm	1420 x 2505 x 1750 mm
Machine weight:	400 kg	580 kg
Fixed rail to front dimension (X):	400 mm	400 mm
Towerlight height (Z):	2000 mm	2000 mm

PCB dimensions

	NTA 730UM	NTA 730UXL
PCB length:	80 - 330 mm	80 - 460 mm*
PCB width:	50 - 250 mm	50 - 460 mm*
PCB thickness :	0,4 - 2,6 mm*	0,4 - 2,6 mm*
PCB weight:	2,5 kg*	2,5 kg*
Magazine dimensions (max.):	355 x 320 x 570 mm	535 x 530 x 570 mm

* Depending on specification.



NTA 731LM • NTA 731LXL

The NTA 731L is a triple magazine line loader with a stationary magazine platform with three magazines placed side by side. The magazines are manually placed and clamped on the platform. The servo driven shuttle conveyor moves in horizontal and vertical direction to align with the magazine and slot position. A puller cylinder extracts a PCB from the magazine onto the shuttle conveyor. An empty magazine can be exchanged at any time. The 7" full colour touchscreen display allows easy operation on multiple user levels.

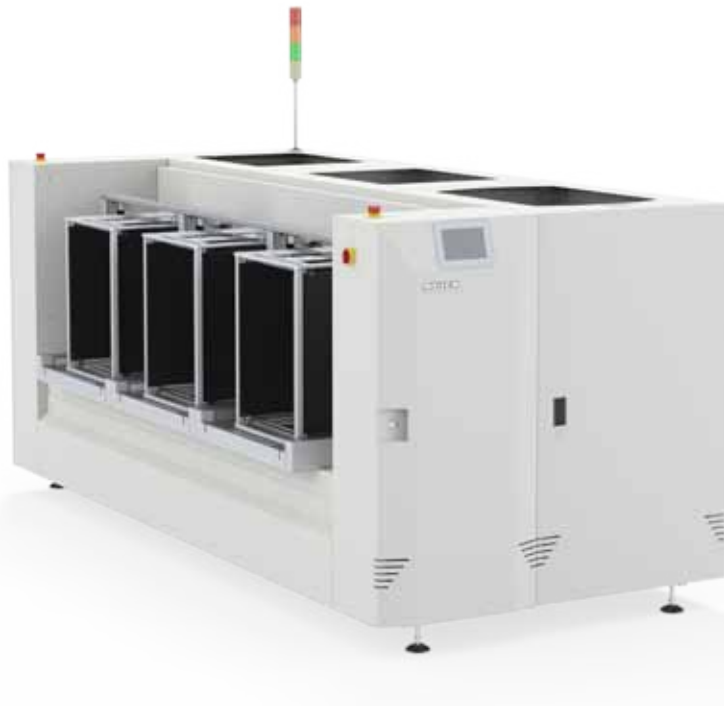

Magazine conveyor.



Rotating puller tip (optional).



7" full colour touchscreen display.

Standard features

- Stationary magazine platform prepared for loading with AGV/AIV.
- Servo driven shuttle conveyor movement (vertical & horizontal).
- Automatic conveyor width adjustment.
- 7" full colour touchscreen display.
- Advanced graphic Human Machine Interface (HMI).
- Multi level user access control.
- In,- & Output diagnostics on touchscreen display.
- Flexible pitch settings.
- 2000 product recipes storage.
- 10 magazine recipes storage.
- Magazine unloading 'top to bottom'.
- Top 5 magazine slots to remain empty.
- Regulated pressure on the puller cylinder.
- Manually adjustable puller position.
- Ethernet connection for network interface.
- Towerlight display for machine status.

Options

- IPC-HERMES-9852 communication.
- Automatic product change-over by Nutek leader - follower software.
- Line Control Software ready.
- Automatic puller positioning.
- Puller position moves in ratio 1:2 with conveyor width.
- Magazine unloading 'bottom to top'.
- Remotely accessible PLC.
- Safety shutter at outlet.
- Rotating puller tip.
- Alarm buzzer.

Other options available on request.

NTA 731LM • NTA 731LXL

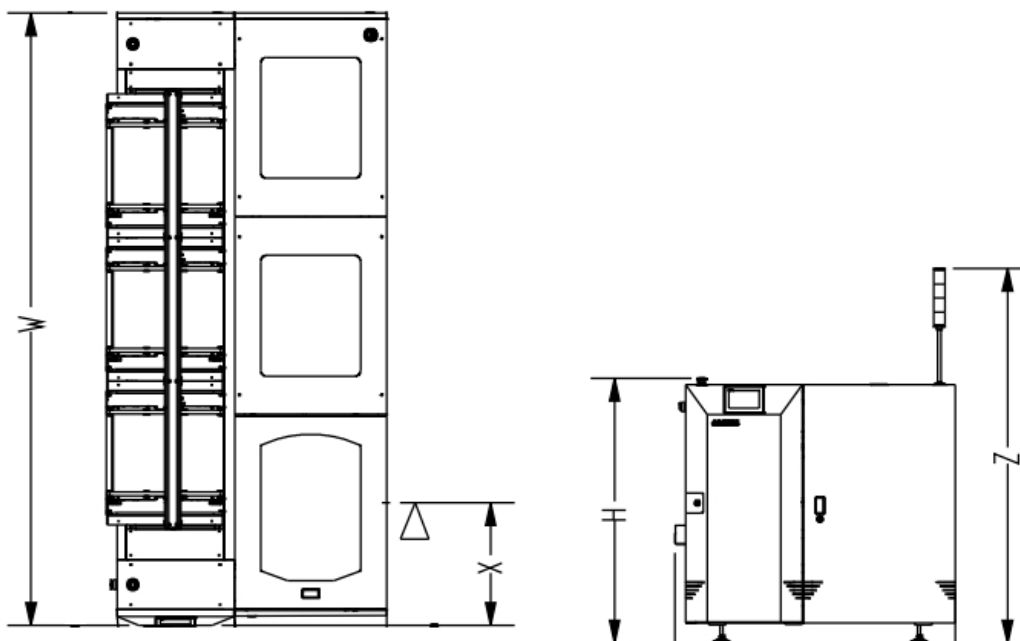

General machine specification

Transfer height:	950 mm ± 25 mm*
Colour:	RAL 9002*
Flow direction:	Left to right*
Fixed rail:	Front*
Machine interface:	IPC-SMEMA-9851*
Components clearance:	Top 30 mm, bottom 30 mm
PCB unloading time:	± 18 seconds (rear magazine)
Pitch control:	Flexible pitch settings
Maximum total magazine weight:	50 kg

Installation requirements

Power supply:	230 VAC/50 Hz/1 Ph
Power consumption:	350 VA max
Air supply:	6 bar
Air consumption:	10 ltr/min max

Machine dimensions

NTA 731LM

NTA 731LXL

Machine dimensions (l x w x h):	1420 x 2185 x 1330 mm	1420 x 3090 x 1330 mm
Machine weight:	330 kg	480 kg
Fixed rail to front dimension (X):	535 mm	535 mm
Towerlight height (Z):	2000 mm	2000 mm

PCB dimensions

NTA 731LM

NTA 731LXL

PCB length:	80 - 330 mm	80 - 460 mm*
PCB width:	50 - 250 mm	50 - 460 mm*
PCB thickness:	0,6 - 2,6 mm*	0,6 - 2,6 mm*
Magazine dimensions (max):	370 x 320 x 570 mm	535 x 580 x 570 mm

* Depending on specification.



NTA 73IUM • NTA 73IUXL

The NTA 731U is a triple magazine line unloader with a stationary magazine platform with three magazines placed side by side. The magazines are manually placed and clamped on the platform, the servo driven shuttle conveyor conveyor is used to collect a PCB from the upstream machine and pushes it into the magazine. A full magazine can be exchanged at any time. The 7" full colour touchscreen display allows easy operation on multiple user levels.

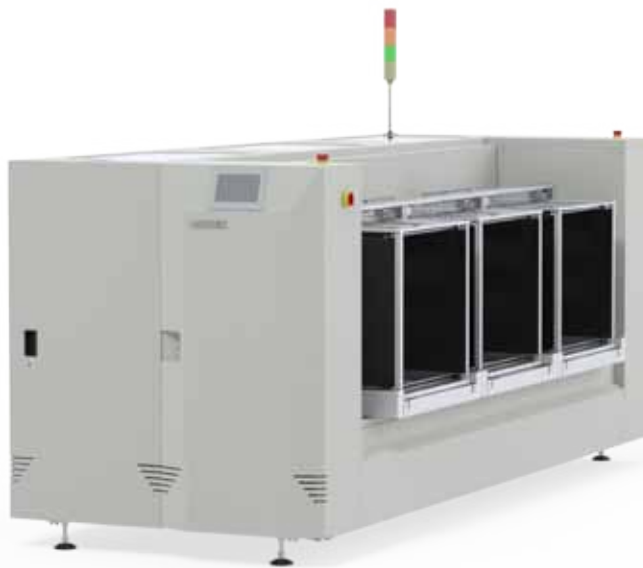

Magazine conveyor.



Shuttle conveyor.



7" full colour touchscreen display.

Standard features

- Stationary magazine platform prepared for loading with AGV/AIV.
- Servo driven traversing movement.
- Servo driven width adjustment on traverser.
- 7" full colour touchscreen display.
- Multi level user access control.
- In,- & Output diagnostics on touchscreen display.
- Flexible pitch settings.
- 2000 product recipes storage.
- 10 magazine recipes storage.
- Regulated pressure on the pusher cylinder.
- Manually adjustable pusher position.
- Oven info threshold signal.
- Good/bad separation function.
- Ethernet connection for network interface.

Options

- Hermes Communication.
- Leader - follower communication.
- Line Control Software ready.
- Automatic pusher positioning.
- Pusher position moves in ratio 1:2 with conveyor width.
- Remotely accessible PLC.
- Safety shutter at inlet.
- Pneumatic stopper, to control PCB flow from upstream reflow oven.
- Intelligent threshold counter to stop PCB infeed into reflow oven.
- Alarm buzzer.

Other options available on request.





NTA 73IUM • NTA 73IUXL

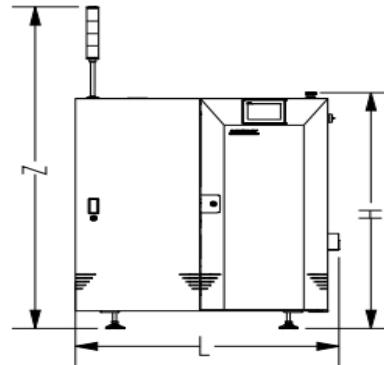
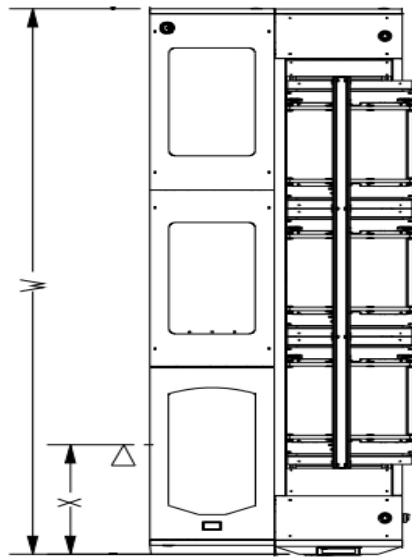

General machine specification

Transfer height:	950 mm ± 25 mm*
Colour:	RAL 9002*
Flow direction:	Left to right*
Fixed rail:	Front*
Machine interface:	IPC-SMEMA-9851*
Components clearance:	Top 30 mm, bottom 30 mm
PCB unloading time:	± 18 seconds (rear magazine)
Pitch control:	Flexible pitch settings
Maximum total magazine weight:	50 kg

Installation requirements

Power supply:	230 VAC/50 Hz/1 Ph
Power consumption:	350 VA max
Air supply:	6 bar
Air consumption:	10 ltr/min max.

Machine dimensions

	NTA 73IUM	NTA 73IUXL
Machine dimensions (l x w x h):	1225 x 2185 x 1330 mm	1225 x 3090 x 1330 mm
Machine weight:	330 kg	480 kg
Fixed rail to front dimension (X):	535 mm	535 mm
Towerlight height (Z):	2000 mm	2000 mm

PCB dimensions

	NTA 73IUM	NTA 73IUXL
PCB length:	80 - 330 mm	80 - 460 mm*
PCB width:	50 - 250 mm	50 - 460 mm*
PCB thickness:	0,6 - 2,6 mm*	0,6 - 2,6 mm*
Magazine dimensions (max.):	370 x 320 x 570 mm	535 x 580 x 570 mm

* Depending on specification.



NTA IIOLM • NTA IIOLXL

The NTA 110L is a multi magazine line loader with a 6 magazine capacity, 3 full magazines are placed on the lower magazine conveyor, 1 magazine is on the servo driven lifter. A pneumatic pusher cylinder pushes the PCB out of the magazine to downstream. The upper magazine conveyor has a capacity for 2 empty magazines. After a magazine is emptied the magazine is automatically exchanged. The 7" full colour touchscreen display allows easy operation on multiple user levels.



Magazine conveyor detail.



7" full colour touchscreen display.

Standard features

- Servo driven lifter platform.
- 7" full colour touchscreen display.
- Advanced graphic Human Machine Interface (HMI).
- Multi level user access control.
- In-, & Output diagnostics on touchscreen display.
- Flexible pitch settings.
- 2000 product recipes storage.
- 10 magazine recipes storage.
- Magazine unloading 'top to bottom' or 'bottom to top'.
- Tailor made to the magazine of your choice.
- Automatic magazine alignment by upper and lower pneumatic clamping.
- High throughput with short magazine change over time.
- Regulated pressure on the pusher cylinder.
- Manually adjustable pusher position.
- Ethernet connection for network interface.
- Towerlight display for machine status.

Options

- IPC-HERMES-9852 communication.
- Automatic product change-over by Nutek leader - follower software.
- Line Control Software ready.
- Automatic pusher positioning.
- Remotely accessible PLC.
- Safety shutter at outlet.
- Increased magazine capacity.
- Reduced magazine capacity.
- Width adjustable magazine conveyors to handle other magazine width.
- Alarm buzzer.

Other options available on request.

NTA IIOLM • NTA IIOLXL

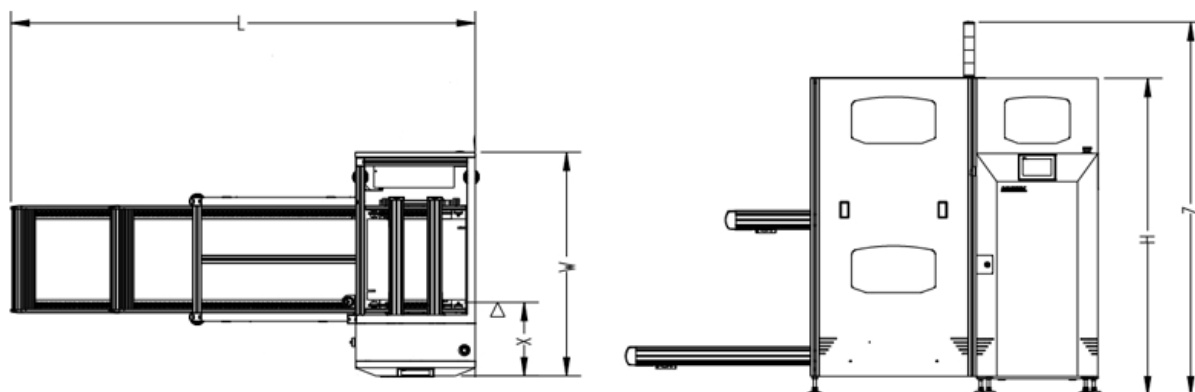

General machine specification

Transfer height:	950 mm ± 25 mm*
Colour:	RAL 9002*
Flow direction:	Left to right*
Fixed rail:	Front*
Machine interface:	IPC-SMEMA-9851*
Components clearance:	Top 30 mm, bottom 30 mm*
PCB loading time:	± 6 seconds
Magazine change over time:	± 22 seconds (top to bottom sequence)
Pitch control:	Flexible pitch settings
Maximum magazine weight:	50 kg (each)

Installation requirements

Power supply:	230 VAC/50 Hz/1 Ph
Power consumption:	620 VA max.
Air supply:	6 bar
Air consumption:	27 ltr/min max.

Machine dimensions

	NTA 110LM	NTA 110LXL
Machine dimensions (l x w x h):	2010 x 995 x 1700 mm	2535 x 1220 x 1700 mm
Machine weight:	235 kg	400 kg
Fixed rail to front dimension (X):	405 mm	405 mm
Towerlight height (Z):	2000 mm	2000 mm

PCB dimensions

	NTA 110LM	NTA 110LXL
PCB length:	80 - 330 mm	80 - 460 mm*
PCB width:	50 - 250 mm	50 - 460 mm*
PCB thickness:	0,4 - 2,6 mm*	0,4 - 2,6 mm*
PCB weight:	2,5 kg*	2,5 kg*
Magazine dimensions (max.):	355 x 320 x 570 mm	535 x 530 x 570 mm

* Depending on specification.



NTA 110UM • NTA 110UXL

The NTA 110U is a multi magazine line unloader with a six magazine capacity, 2 empty magazines are placed on the upper magazine conveyor, 1 magazine is on the servo driven lifter. The upstream pusher conveyor pushes the PCB completely in the magazine. The lower magazine conveyor has a capacity for 3 full magazines. After a magazine is filled the magazine is automatically exchanged. The 7" full colour touchscreen display allows easy operation on multiple user levels.



Magazine conveyor detail.



7" full colour touchscreen display.

Standard features

- Servo driven lifter platform.
- 7" full colour touchscreen display.
- Advanced graphic Human Machine Interface (HMI).
- Multi level user access control.
- In-, & Output diagnostics on touchscreen display.
- Flexible pitch settings.
- 2000 product recipes storage.
- 10 magazine recipes storage.
- Magazine loading 'top to bottom' or 'bottom to top'.
- Tailor made to the magazine of your choice.
- Automatic magazine alignment by upper and lower pneumatic clamping.
- High throughput with short magazine change over time.
- Ethernet connection for network interface.
- Towerlight display for machine status.

Options

- IPC-HERMES-9852 communication.
- Automatic product change-over by Nutek leader - follower software.
- Line Control Software ready.
- Remotely accessible PLC.
- Increased magazine capacity.
- Reduced magazine capacity.
- Width adjustable magazine conveyors to handle other magazine width.
- Alarm buzzer.

Other options available on request

Note: pusher conveyor to be ordered separately.

NTA 110UM • NTA 110UXL

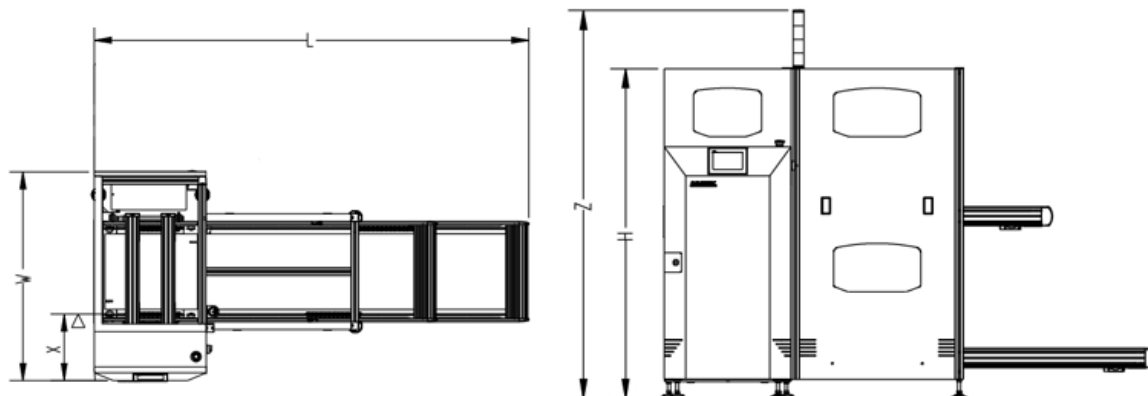

General machine specification

Transfer height:	950 mm ± 25 mm*
Colour:	RAL 9002*
Flow direction:	Left to right*
Fixed rail:	Front*
Machine interface:	IPC-SMEMA-9851*
Components clearance:	Top 30 mm, bottom 30 mm*
PCB unloading time:	± 6 seconds
Magazine change over time:	± 22 seconds (bottom to top sequence)
Pitch control:	Flexible pitch settings
Maximum magazine weight:	50 kg (each)

Installation requirements

Power supply:	230 VAC/50 Hz/1 Ph
Power consumption:	740 VA max (including separate pusher conveyor)
Air supply:	6 bar
Air consumption:	27 ltr/min max

Machine dimensions

	NTA 110UM	NTA 110UXL
Machine dimensions (l x w x h):	2010 x 995 x 1700 mm	2535 x 1220 x 1700 mm
Machine weight:	235 kg	400 kg
Fixed rail to front dimension (X):	405 mm	405 mm
Towerlight height (Z):	2000 mm	2000 mm

PCB dimensions

	NTA 110UM	NTA 110UXL
PCB length:	80 - 330 mm	80 - 460 mm*
PCB width:	50 - 250 mm	50 - 460 mm*
PCB thickness:	0,4 - 2,6 mm*	0,4 - 2,6 mm*
PCB weight:	2,5 kg*	2,5 kg*
Magazine dimensions (max.):	355 x 320 x 570 mm	535 x 530 x 570 mm

* Depending on specification.

NTA I15LM • NTA I15LXL

The NTA 115L is a multi magazine line loader with a 7 magazine capacity. This line loader has 2 magazine conveyors placed side by side for convenient magazine exchange at ergonomic height, 1 for full magazines, 1 for empty magazines (capacity of 3 magazines each) . 1 magazine is on the servo driven lifter/shuttle conveyor. A pneumatic pusher cylinder pushes the PCB out of the magazine to downstream. Magazines are automatically changed over.

The 7" full colour touchscreen display allows easy operation on multiple user levels.



Magazine conveyor.



7" full colour touchscreen display.

Standard features

- Servo driven lifter movement (vertical & horizontal).
- 7" full colour touchscreen display.
- Advanced graphic Human Machine Interface (HMI).
- Multi level user access control.
- In,- & Output diagnostics on touchscreen display.
- Flexible pitch settings.
- 2000 product recipes storage.
- 10 magazine recipes storage.
- Magazine unloading 'top to bottom' or 'bottom to top'.
- Tailor made to the magazine of your choice.
- Automatic magazine alignment by upper and lower pneumatic clamping.
- High throughput with short magazine change over time.
- Regulated pressure on the pusher cylinder.
- Manually adjustable pusher position.
- Ethernet connection for network interface.
- Towerlight display for machine status.

Options

- IPC-HERMES-9852 communication.
- Automatic product change-over by Nutek leader - follower software.
- Line Control Software ready.
- Automatic pusher positioning.
- Remotely accessible PLC.
- Safety shutter at outlet.
- Increased magazine capacity.
- Reduced magazine capacity.
- Width adjustable magazine conveyors to handle other magazine width.
- AGV/AIV prepared.
- Alarm buzzer.

Other options available on request.



NTA 115LM • NTA 115LXL

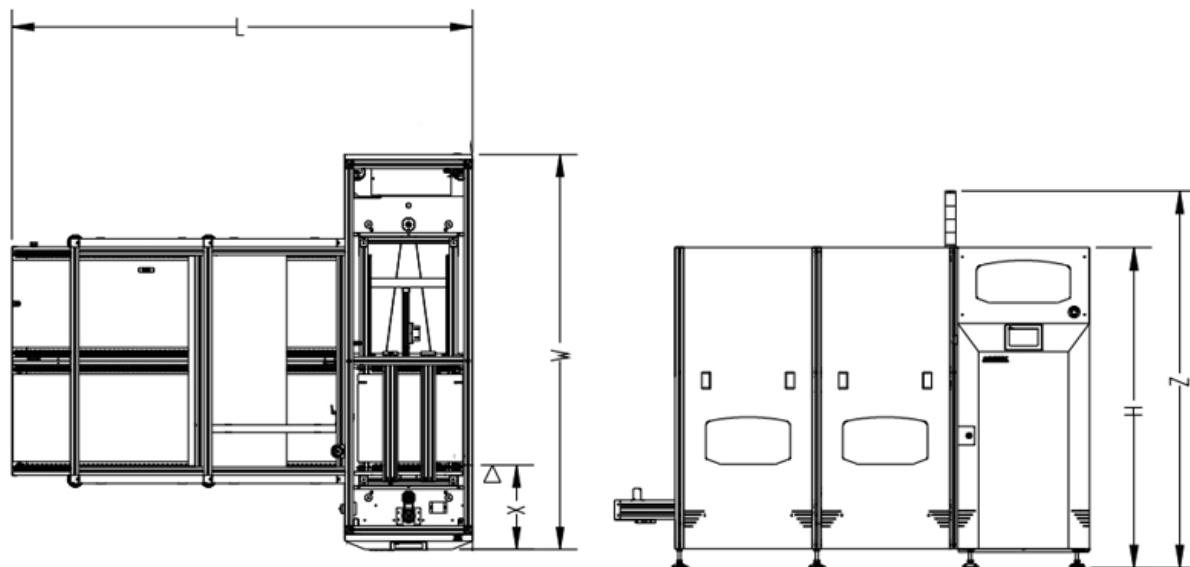

General machine specification

Transfer height:	950 mm ± 25 mm*
Colour:	RAL 9002*
Flow direction:	Left to right*
Fixed rail:	Front*
Machine interface:	IPC-SMEMA-9851*
Components clearance:	Top 30 mm, bottom 30 mm*
PCB loading time:	± 6 seconds
Magazine change over time:	± 22 seconds (top to bottom sequence)
Pitch control:	Flexible pitch settings
Maximum magazine weight:	50 kg (each)

Installation requirements

Power supply:	230 VAC/50 Hz/1 Ph
Power consumption:	620 VA max
Air supply:	6 bar
Air consumption:	27 ltr/min max

Machine dimensions

	NTA 115LM	NTA 115LXL
Machine dimensions (l x w x h):	1800 x 1540 x 1700 mm	2530 x 2165 x 1700 mm
Machine weight:	400 kg	580 kg
Fixed rail to front dimension (X):	460 mm	460 mm
Towerlight height (Z):	2000 mm	2000 mm

PCB dimensions

	NTA 115LM	NTA 115LXL
PCB length:	80 - 330 mm	80 - 460 mm*
PCB width:	50 - 250 mm	50 - 460 mm*
PCB thickness:	0,4 - 2,6 mm*	0,4 - 2,6 mm*
PCB weight:	2,5 kg*	2,5 kg*
Magazine dimensions (max.):	355 x 320 x 570 mm	535 x 530 x 570 mm

* Depending on specification.



NTA IISUM • NTA IISUXL

The NTA 115U is a multi magazine line unloader with a 7 magazine capacity. This line loader has 2 magazine conveyors placed side by side for convenient magazine exchange at ergonomic height, 1 for full magazines, 1 for empty magazines (capacity of 3 magazines each) . 1 magazine is on the servo driven lifter/shuttle conveyor. The upstream pusher conveyor pushes the PCB completely in the magazine. Magazines are automatically changed over.

The 7" full colour touchscreen display allows easy operation on multiple user levels.



Magazine conveyor.



7" full colour touchscreen display.

Standard features

- Servo driven lifter movement (vertical & horizontal).
- 7" full colour touchscreen display.
- Advanced graphic Human Machine Interface (HMI).
- Multi level user access control.
- In,- & Output diagnostics on touchscreen display.
- Flexible pitch settings.
- 2000 product recipes storage.
- 10 magazine recipes storage.
- Magazine loading 'top to bottom' or 'bottom to top'.
- Tailor made to the magazine of your choice.
- Automatic magazine alignment by upper and lower pneumatic clamping.
- High throughput with short magazine change over time.
- Ethernet connection for network interface.
- Towerlight display for machine status.

Options

- IPC-HERMES-9852 communication.
- Automatic product change-over by Nutek leader - follower software.
- Line Control Software ready.
- Remotely accessible PLC.
- Increased magazine capacity.
- Reduced magazine capacity.
- Width adjustable magazine conveyors to handle other magazine width.
- Alarm buzzer.

Other options available on request.

Note: pusher conveyor to be ordered separately.

NTA I15UM • NTA I15UXL

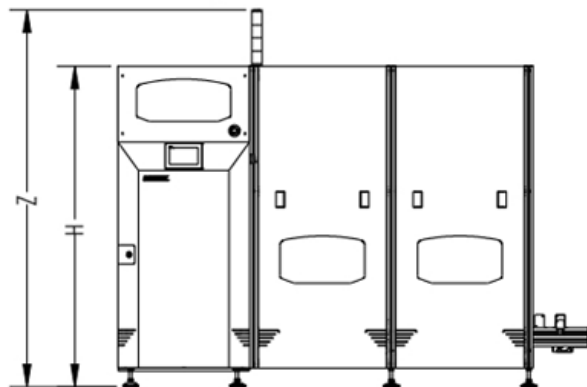
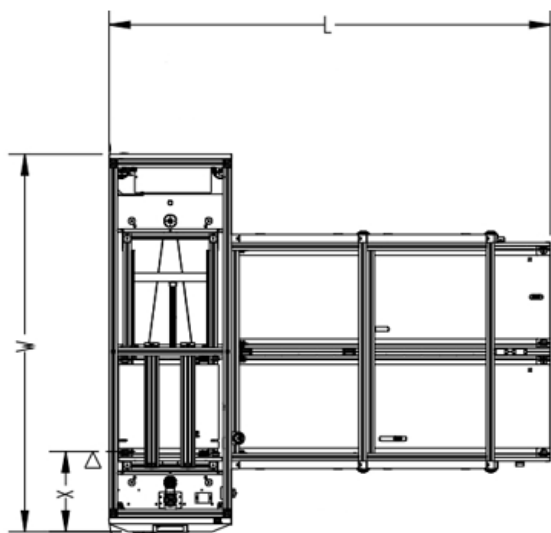

General machine specification

Transfer height:	950 mm ± 25 mm*
Colour:	RAL 9002*
Flow direction:	Left to right*
Fixed rail:	Front*
Machine interface:	IPC-SMEMA-9851*
Components clearance:	Top 30 mm, bottom 30 mm*
PCB unloading time:	± 6 seconds
Magazine change over time:	± 22 seconds (bottom to top sequence)
Pitch control:	Flexible pitch settings
Maximum magazine weight:	50 kg (each)

Installation requirements

Power supply:	230 VAC/50 Hz/1 Ph
Power consumption:	740 VA max (including separate pusher conveyor)
Air supply:	6 bar
Air consumption:	27 ltr/min max

Machine dimensions

	NTA 115UM	NTA 115UXL
Machine dimensions (l x w x h):	1800 x 1540 x 1700 mm	2530 x 2165 x 1700 mm
Machine weight:	400 kg	580 kg
Fixed rail to front dimension (X):	460 mm	460 mm
Towerlight height (Z):	2000 mm	2000 mm

PCB dimensions

	NTA 115LM	NTA 115LXL
PCB length:	80 - 330 mm	80 - 460 mm*
PCB width:	50 - 250 mm	50 - 460 mm*
PCB thickness:	0,4 - 2,6 mm*	0,4 - 2,6 mm*
PCB weight:	2,5 kg*	2,5 kg*
Magazine dimensions (max.):	355 x 320 x 570 mm	535 x 530 x 570 mm

* Depending on specification.

NTA I20LM • NTA I20LXL

The NTA 120L is a multi magazine line loader with a 6 magazine capacity, 3 full magazines are placed on the lower magazine conveyor, 1 magazine is on the servo driven lifter. A pneumatic pusher cylinder pushes the PCB out of the magazine to downstream. The upper magazine conveyor has a capacity for 2 empty magazines. After a magazine is emptied the magazine is automatically exchanged. This loader has a reduced length as the magazine conveyors are positioned at a 90° angle. The 7" full colour touchscreen display allows easy operation on multiple user levels.



Magazine conveyor detail.



7" full colour touchscreen display.

Standard features

- Servo driven lifter platform.
- 7" full colour touchscreen display.
- Advanced graphic Human Machine Interface (HMI).
- Multi level user access control.
- In-, & Output diagnostics on touchscreen display.
- Flexible pitch settings.
- 2000 product recipes storage.
- 10 magazine recipes storage.
- Magazine unloading 'top to bottom' or 'bottom to top'.
- Tailor made to the magazine of your choice.
- Automatic magazine alignment by upper and lower pneumatic clamping.
- High throughput with short magazine change over time.
- Regulated pressure on the pusher cylinder.
- Manually adjustable pusher position.
- Ethernet connection for network interface.
- Towerlight display for machine status.

Options

- IPC-HERMES-9852 communication.
- Automatic product change-over by Nutek leader - follower software.
- Line Control Software ready.
- Automatic pusher positioning.
- Remotely accessible PLC.
- Safety shutter at outlet.
- Increased magazine capacity.
- Reduced magazine capacity.
- Width adjustable magazine conveyors to handle other magazine length.
- Front side magazine loading.
- Alarm buzzer.

Other options available on request.



NTA I20LM • NTA I20LXL

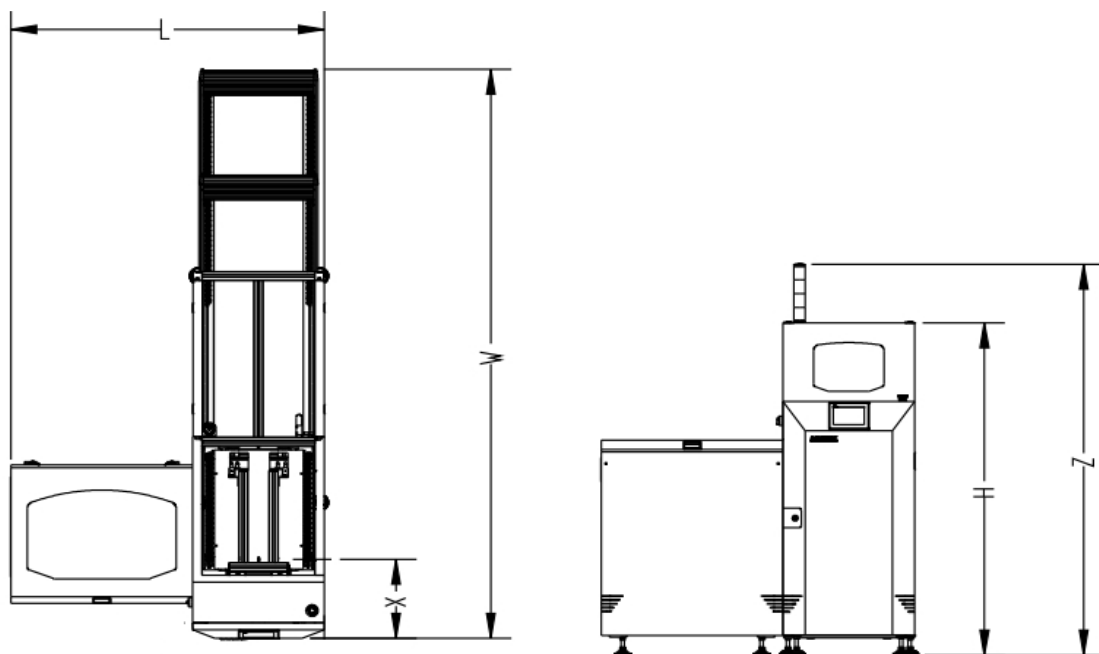

General machine specification

Transfer height:	950 mm ± 25 mm*
Colour:	RAL 9002*
Flow direction:	Left to right*
Fixed rail:	Front*
Machine interface:	IPC-SMEMA-9851*
Components clearance:	Top 30 mm, bottom 30 mm*
PCB loading time:	± 6 seconds
Magazine change over time:	± 22 seconds (top to bottom sequence)
Pitch control:	Flexible pitch settings
Maximum magazine weight:	50 kg (each)

Installation requirements

Power supply:	230 VAC/50 Hz/1 Ph
Power consumption:	620 VA max
Air supply:	6 bar
Air consumption:	27 ltr/min max

Machine dimensions

	NTA 120LM	NTA 120LXL
Machine dimensions (l x w x h):	1200 x 2165 x 1700 mm	1560 x 2915 x 1700 mm
Machine weight:	260 kg	430 kg
Fixed rail to front dimension (X):	405 mm	405 mm
Towerlight height (Z):	2000 mm	2000 mm

PCB dimensions

	NTA 120LM	NTA 120LXL
PCB length:	80 - 330 mm	80 - 460 mm*
PCB width:	50 - 250 mm	50 - 460 mm*
PCB thickness:	0,4 - 2,6 mm*	0,4 - 2,6 mm*
PCB weight:	2,5 kg*	2,5 kg*
Magazine dimensions (max.):	355 x 320 x 570 mm	535 x 530 x 570 mm

* Depending on specification,



NTA I20UM • NTA I20UXL

The NTA 120U is a multi magazine line unloader with a 6 magazine capacity, 2 empty magazines are placed on the upper magazine conveyor, 1 magazine is on the servo driven lifter. A pneumatic pusher cylinder pushes the PCB out of the magazine to downstream.

The lower magazine conveyor has a capacity for 3 full magazines. After a magazine is filled the magazine is automatically exchanged.

This unloader has a reduced length as the magazine conveyors are positioned at a 90° angle.

The 7" full colour touchscreen display allows easy operation on multiple user levels.



Magazine conveyor detail.



7" full colour touchscreen display.

Standard features

- Servo driven lifter platform.
- 7" full colour touchscreen display.
- Advanced graphic Human Machine Interface (HMI).
- Multi level user access control.
- In-, & Output diagnostics on touchscreen display.
- Flexible pitch settings.
- 2000 product recipes storage.
- 10 magazine recipes storage.
- Magazine unloading 'top to bottom' or 'bottom to top'.
- Tailor made to the magazine of your choice.
- Automatic magazine alignment by upper and lower pneumatic clamping.
- High throughput with short magazine change over time.
- Regulated pressure on the pusher cylinder.
- Manually adjustable pusher position.
- Ethernet connection for network interface.
- Towerlight display for machine status.

Options

- IPC-HERMES-9852 communication.
- Automatic product change-over by Nutek leader - follower software.
- Line Control Software ready.
- Automatic pusher positioning.
- Remotely accessible PLC.
- Safety shutter at outlet.
- Increased magazine capacity.
- Reduced magazine capacity.
- Width adjustable magazine conveyors to handle other magazine length.
- Front side magazine loading.
- Alarm buzzer.

Other options available on request.



NTA I20UM • NTA I20UXL

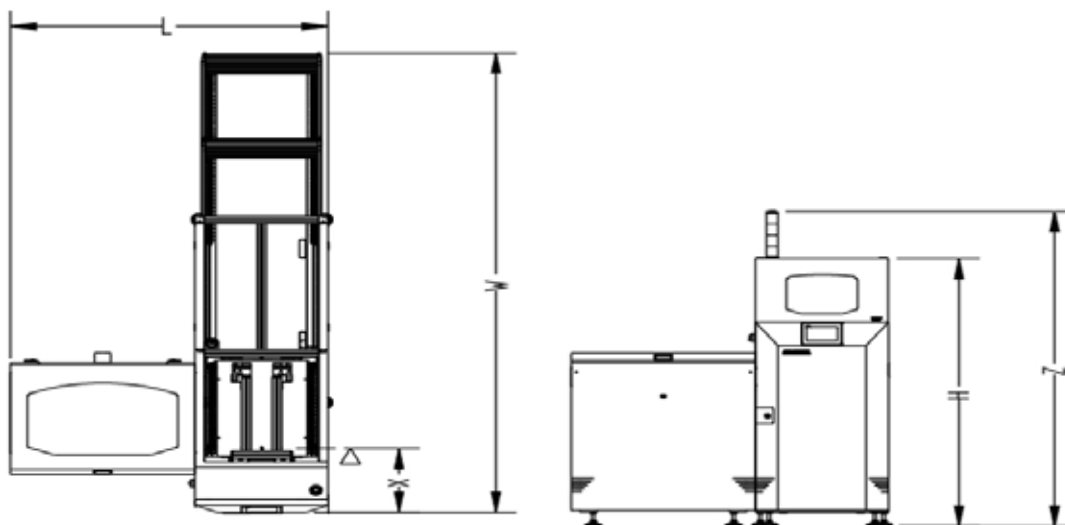

General machine specification

Transfer height:	950 mm ± 25 mm*
Colour:	RAL 9002*
Flow direction:	Left to right*
Fixed rail:	Front*
Machine interface:	IPC-SMEMA-9851*
Components clearance:	Top 30 mm, bottom 30 mm*
PCB loading time:	± 6 seconds
Magazine change over time:	± 22 seconds (top to bottom sequence)
Pitch control:	Flexible pitch settings
Maximum magazine weight:	50 kg (each)

Installation requirements

Power supply:	230 VAC/50 Hz/1 Ph
Power consumption:	620 VA max
Air supply:	6 bar
Air consumption:	27 ltr/min max

Machine dimensions

	NTA 120UM	NTA 120UL
Machine dimensions (l x w x h):	1200 x 2165 x 1700 mm	1560 x 2915 x 1700 mm
Machine weight:	260 kg	430 kg
Fixed rail to front dimension (X):	405 mm	405 mm
Towerlight height (Z):	2000 mm	2000 mm

PCB dimensions

	NTA 120UM	NTA 120UXL
PCB length:	80 - 330 mm	80 - 460 mm*
PCB width:	50 - 250 mm	50 - 460 mm*
PCB thickness:	0,4 - 2,6 mm*	0,4 - 2,6 mm*
PCB weight:	2,5 kg*	2,5 kg*
Magazine dimensions (max.):	355 x 320 x 570 mm	535 x 530 x 570 mm

* Depending on specification.

NTA IIOPM • NTA IIOPXL

The NTA 110P is a pusher conveyor and is used in combination with any multi magazine line unloader.

The pusher conveyor is controlled by the multi magazine line unloader and guarantees that PCB's are completely pushed into the magazine.



Pusher conveyor control.

Standard features

- Controlled by multi magazine line unloader.
- Automatic conveyor width adjustment.
- Regulated pressure on the pusher cylinder.
- Manually adjustable pusher position.

Options

- Automatic pusher positioning.
- Pusher position moves in ratio 1:2 with conveyor width.
- Safety shutter at inlet.

Other options available on request.



NTA IIOPM • NTA IIOPXL

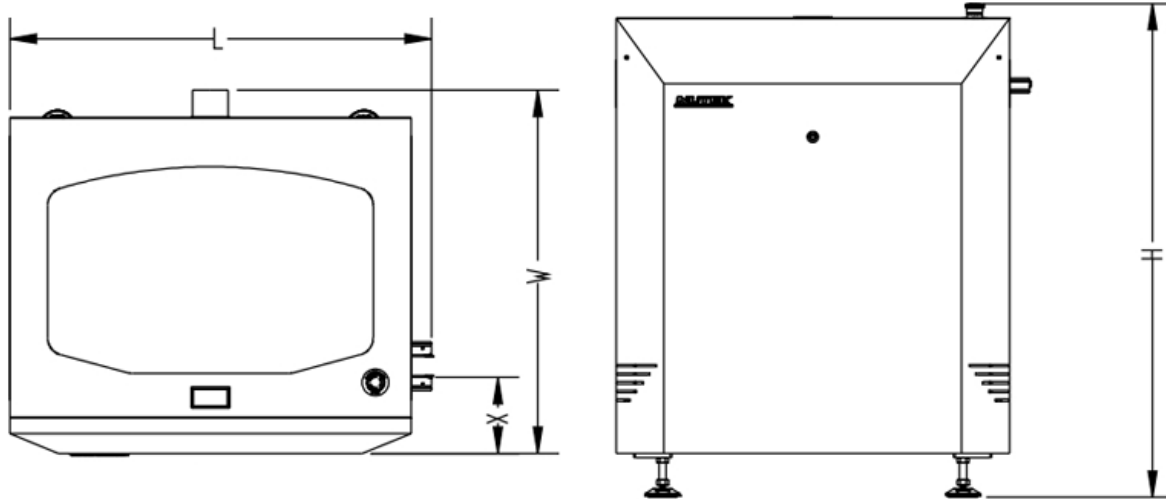

General machine specification

Transfer height:	950 mm ± 25 mm*
Colour:	RAL 9002*
Flow direction:	Left to right*
Fixed rail:	Front*
Machine interface:	IPC-SMEMA-9851*
Components clearance:	Top 30 mm, bottom 30 mm
Belt speed:	14 m/min
PCB edge support:	3 mm

Installation requirements

Power supply:	Controlled by unloader
Power consumption:	Controlled by unloader
Air supply:	Controlled by unloader
Air consumption:	Controlled by unloader

Machine dimensions	NTA 110PM	NTA 110PXL
Machine dimensions (l x w x h):	755 x 590 x 1130 mm	950 x 820 x 1130 mm
Machine weight:	70 kg	100 kg
Fixed rail to front dimension (X):	175 mm	175 mm

PCB dimensions	NTA 110PM	NTA 110PXL
PCB length:	80 - 330 mm	80 - 460 mm*
PCB width:	50 - 250 mm	50 - 460 mm*
PCB thickness:	0,4 - 2,6 mm*	0,4 - 2,6 mm*
PCB weight:	2,5 kg*	2,5 kg*

* Depending on specification.



NTA 210BMBP • NTA 210BXLBP

The NTA 210B is a bare board loader designed to automatically load PCB's from a stack to the downstream machine. PCB stack is located under the conveyor segment. The upper pcb is lifted from the stack by use of suction cups (vacuum) and lowered onto the ESD edge belt segment. Stack loading is done by opening the front door. The 7" full colour touchscreen display allows easy operation on multiple user levels.



Suction cups.



7" full colour touchscreen display.

Standard features

- Automatic conveyor width adjustment.
- 7" full colour touchscreen display.
- Advanced graphic Human Machine Interface (HMI).
- Multi level user access control.
- In,- & Output diagnostics on touchscreen display.
- 2000 product recipes storage.
- Bypass mode selectable without removing PCB stack.
- Low stack prewarning.
- Top safety cover can be opened for easy access.
- Thin and fragile PCB capability.
- Adjustable suction cup positioning for better grip of PCB's.
- Ethernet connection for network interface.
- Towerlight display for machine status.

Options

- IPC-HERMES-9852 communication.
- Automatic product change-over by Nutek leader - follower software.
- Line Control Software ready.
- Remotely accessible PLC.
- Cantilevered input or output conveyor (500mm).
- Safety shutter at in,- or outlet.
- Alternative suction cup size.
- Additional set of suction cups.
- Alarm buzzer.

Other options available on request.

NTA 210BMBP • NTA 210BXLBP

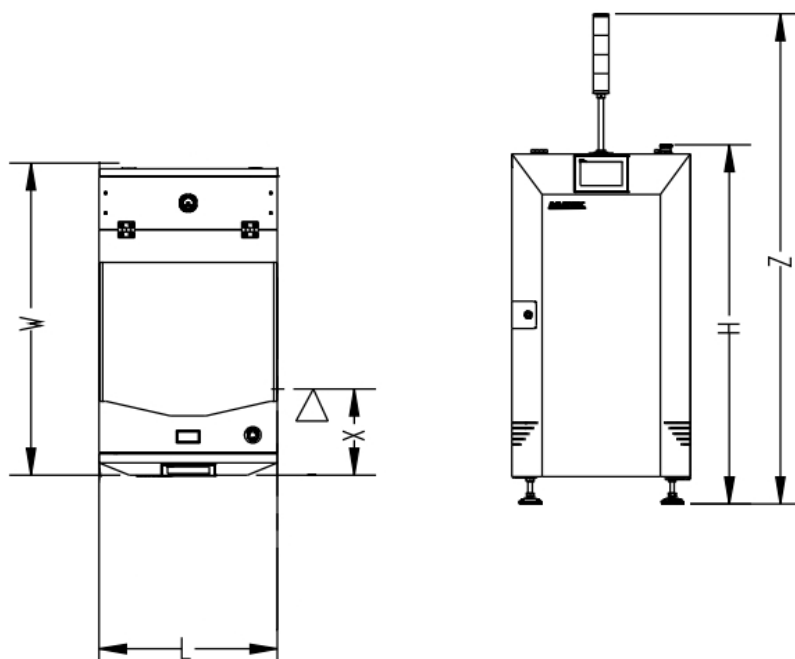

General machine specification

Transfer height:	950 mm ± 25 mm*
Colour:	RAL 9002*
Flow direction:	Left to right*
Fixed rail:	Front*
Machine interface:	IPC-SMEMA-9851*
Components clearance:	Top 30 mm, bottom 30 mm
Belt speed:	14 m/min
PCB edge support:	3 mm
PCB cycle time:	±10 seconds*
PCB Stock capacity:	220 mm
Diameter suction pads:	15 mm

Installation requirements

Power supply:	230 VAC/50 Hz/1 Ph
Power consumption:	190 VA max
Air supply:	6 bar
Air consumption:	90 ltr/min max

Machine dimensions

	NTA 210BMBP	NTA 210BXLBP
Machine dimensions (l x w x h):	500 x 965 x 1330 mm	653 x 1155 x 1330 mm
Machine weight:	110 kg	160 kg
Fixed rail to front dimension (X):	258 mm	258 mm
Towerlight height (Z):	2000 mm	2000 mm

PCB dimensions

	NTA 210BMBP	NTA 210BXLBP
PCB length :	80 - 330 mm	80 - 460 mm*
PCB width :	50 - 250 mm	50 - 460 mm*
PCB thickness :	0,2 - 4 mm*	0,2 - 4 mm*
PCB weight:	2,5 kg*	2,5 kg*

* Depending on specification.

NTA 220DSM • NTA 220DSXL

The NTA 220DS is a bare board loader designed to automatically load PCB's from a stack to the downstream machine. PCB stack is located above the conveyor segment. The bottom pcb is separated from the stack by unique separation cams and lowered onto the ESD edge belt segment. The open design allows continuous stack loading without stopping operation. The 7" full colour touchscreen display allows easy operation on multiple user levels.



Separation cams.



7" full colour touchscreen display.

Standard features

- Automatic conveyor width adjustment.
- 7" full colour touchscreen display.
- Advanced graphic Human Machine Interface (HMI).
- Multi level user access control.
- In,- & Output diagnostics on touchscreen display.
- 2000 product recipes storage.
- Bypass mode selectable without removing PCB stack.
- Low stack prewarning.
- Ethernet connection for network interface.
- Towerlight display for machine status.

Options

- IPC-HERMES-9852 communication.
- Automatic product change-over by Nutek leader - follower software.
- Line Control Software ready.
- Remotely accessible PLC.
- Automatic PCB thickness adjustment.
- Cantilevered input or output conveyor (500mm).
- Sliding topcover for dust protection.
- Conveyor rail extension of 200mm.
- Alarm buzzer.

Other options available on request.



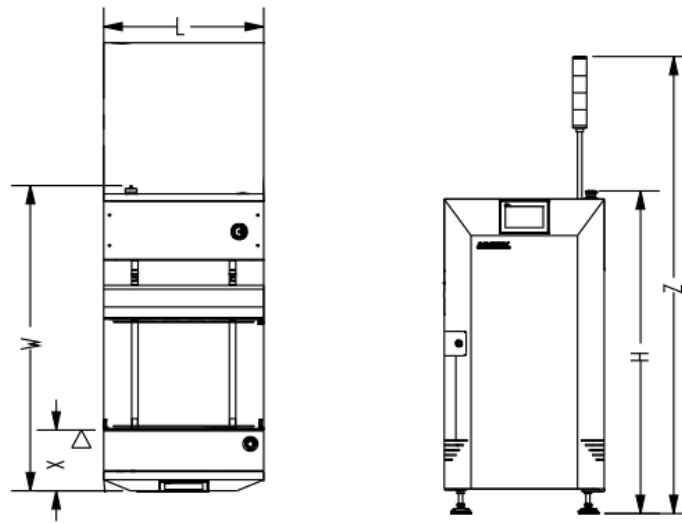

General machine specification

Transfer height:	950 mm ± 25 mm*
Colour:	RAL 9002*
Flow direction:	Left to right*
Fixed rail:	Front*
Machine interface:	IPC-SMEMA-9851*
Components clearance:	Top 30 mm, bottom 30 mm
Belt speed:	14 m/min
PCB edge support:	3 mm
PCB cycle time:	± 8 seconds
PCB Stock capacity:	220 mm
PCB Stack weight:	30 kg (max.)

Installation requirements

Power supply:	230 VAC/50 Hz/1 Ph
Power consumption:	190 VA max.
Air supply:	6 bar
Air consumption:	5 ltr/min max.

Machine dimensions	NTA 220DSM	NTA 220DSXL
Machine dimensions (l x w x h):	500 x 1205 x 1330 mm	653 x 1260 x 1330 mm
Machine weight:	150 kg	160 kg
Fixed rail to front dimension (X):	247 mm	247 mm
Towerlight height (Z):	2000 mm	2000 mm

PCB dimensions	NTA 220DSM	NTA 220DSXL
PCB length:	80 - 330 mm	80 - 460 mm*
PCB width:	50 - 250 mm	50 - 460 mm*
PCB thickness:	0,6 - 4 mm*	0,6 - 4 mm*
PCB weight:	2,5 kg*	2,5 kg*

* Depending on specification.



NTA 225DSM • NTA 225DSXL

The NTA 225DS is a bare board loader designed to automatically load PCB's from a stack to the downstream machine. PCB stack is located under the conveyor segment. The upper pcb is separated from the stack by use of a clamping system and lowered onto the ESD edge belt segment. Stack loading is done by opening the topcover and placing the PCB's on the motorized lifter platform. The 7" full colour touchscreen display allows easy operation on multiple user levels.



7" full colour touchscreen display.

Standard features

- Automatic conveyor width adjustment.
- Motorized lifter platform.
- 7" full colour touchscreen display.
- Advanced graphic Human Machine Interface (HMI).
- Multi level user access control.
- In,- & Output diagnostics on touchscreen display.
- 2000 product recipes storage.
- Bypass mode selectable without removing PCB stack.
- Ethernet connection for network interface.
- Low stack prewarning.
- Towerlight display for machine status.

Options

- IPC-HERMES-9852 communication.
- Automatic product change-over by Nutek leader - follower software.
- Line Control Software ready.
- Remotely accessible PLC.
- Cantilevered input or output conveyor (500mm).
- Safety shutter at in,- or outlet.
- Alarm buzzer.

Other options available on request.



NTA 225DSM • NTA 225DSXL

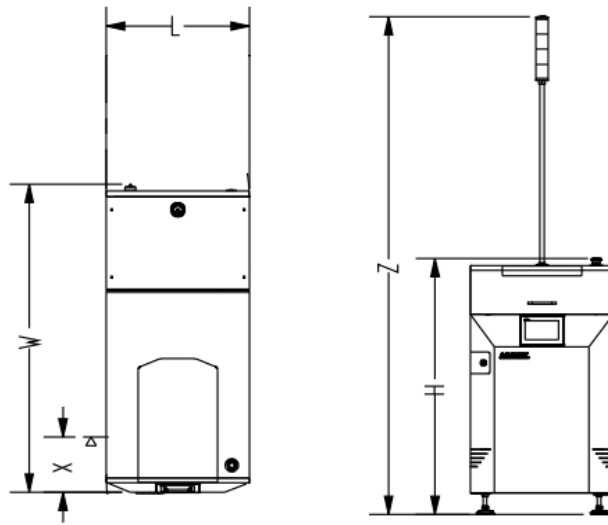

General machine specification

Transfer height:	950 mm ± 25 mm*
Colour:	RAL 9002*
Flow direction:	Left to right*
Fixed rail:	Front*
Machine interface:	IPC-SMEMA-9851*
Components clearance:	Top 30 mm, bottom 30 mm
Belt speed:	14 m/min
PCB edge support:	3 mm
PCB cycle time:	± 8 seconds
PCB Stack capacity:	220 mm
PCB Stack weight:	30 kg (max.)

Installation requirements

Power supply:	230 VAC/50 Hz/1 Ph
Power consumption:	370 VA max
Air supply:	6 bar
Air consumption:	5 ltr/min max

Machine dimensions	NTA 225DSM	NTA 225DSXL
Machine dimensions (l x w x h):	653 x 1430 x 1185 mm	653 x 1430 x 1185 mm
Machine weight:	180 kg	180 kg
Fixed rail to front dimension (X):	256 mm	256 mm
Towerlight height (Z):	2000 mm	2000 mm

PCB dimensions	NTA 225DSM	NTA 225DSXL
PCB length:	80 - 330 mm	80 - 460 mm*
PCB width:	50 - 250 mm	50 - 460 mm*
PCB thickness:	0,8 - 4 mm	0,8 - 4 mm
PCB weight:	2,5 kg*	2,5 kg*

* Depending on specification.



NTA 230PSM • NTA 230PSXL

The NTA 230PS is a bare board unloader designed to automatically restack unpopulated PCB's from upstream machine. PCB stack is located above the conveyor segment. The PCB coming from upstream will be lifted from the conveyor and added to the bottom of the stack. The open design allows continuous stack unloading without stopping operation. The 7" full colour touchscreen display allows easy operation on multiple user levels.



7" full colour touchscreen display.

Standard features

- Automatic conveyor width adjustment.
- 7" full colour touchscreen display.
- Advanced graphic Human Machine Interface (HMI).
- Multi level user access control.
- In,- & Output diagnostics on touchscreen display.
- 2000 product recipes storage.
- Full stack prewarning.
- Ethernet connection for network interface.
- Towerlight display for machine status.

Options

- IPC-HERMES-9852 communication.
- Automatic product change-over by Nutek leader - follower software.
- Line Control Software ready.
- Remotely accessible PLC.
- Cantilevered input conveyor (500mm).
- Double stack function for re-stacking fragile boards.
- Bypass mode.
- Alarm buzzer.

Other options available on request.



NTA 230PSM • NTA 230PSXL

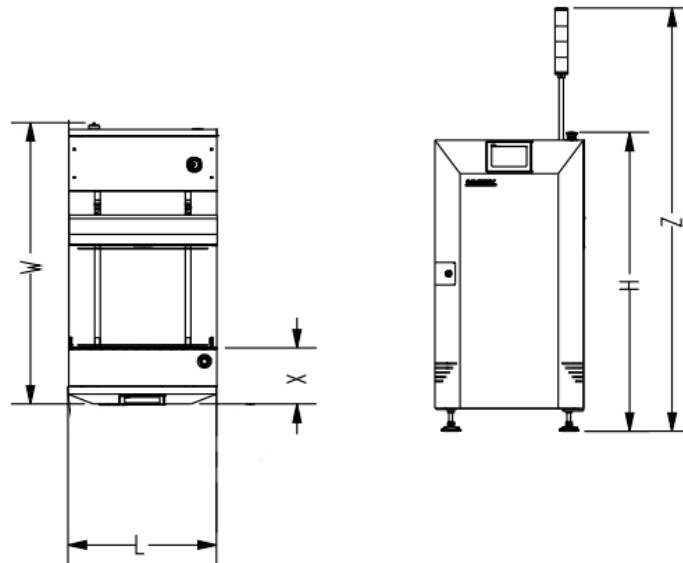

General machine specification

Transfer height:	950 mm ± 25 mm*
Colour:	RAL 9002*
Flow direction:	Left to right*
Fixed rail:	Front*
Machine interface:	IPC-SMEMA-9851*
Components clearance:	Top 30 mm, bottom 30 mm
Belt speed:	14 m/min
PCB edge support:	3 mm
PCB cycle time:	± 9 seconds
PCB Stock capacity:	220 mm.)
PCB Stack weighth:	30 kg (max)

Installation requirements

Power supply:	230 VAC/50 Hz/1 Ph
Power consumption:	190 VA max
Air supply:	6 bar
Air consumption:	5 ltr/min max

Machine dimensions

	NTA 230PSM	NTA 230PSXL
Machine dimensions (l x w x h):	500 x 1205 x 1330 mm	653 x 1260 x 1330 mm
Machine weight:	120 kg	180 kg
Fixed rail to front dimension (X):	247 mm	247 mm
Towerlight height (Z):	2000 mm	2000 mm

PCB dimensions

	NTA 230PSM	NTA 230PSXL
PCB length:	80 - 330 mm	80 - 460 mm*
PCB width:	50 - 250 mm	50 - 460 mm*
PCB thickness:	0,6 - 4 mm*	0,6 - 4 mm*
PCB weighth:	2,5 kg*	2,5 kg*

* Depending on specification.

NTA 4IOM • NTA 4IOXL

The NTA 410 series is used to link process machines or board handling units in a PCB production line. The linking conveyor is available in multiple standard or custom made lengths.

The 4.3" full colour touchscreen display allows easy operation on multiple user levels.



Conveyor detail.



4,3" colour touchscreen display.

Standard features

- Automatic conveyor width adjustment.
- 4,3" full colour touchscreen display.
- Advanced graphic Human Machine Interface (HMI).
- Multi level user access control.
- In,- & Output diagnostics on touchscreen display.
- 2000 product recipes storage.
- Ethernet connection for network interface.
- Standard lengths; 500 mm, 1000 mm, 1500 mm and 2000 mm.
- Stainless steel PCB side guides.

Options

- IPC-HERMES-9852 communication.
- Automatic product change-over by Nutek leader - follower software.
- Line Control Software ready.
- Remotely accessible PLC.
- Custom made length upon specification.
- Multi zone concept.
- Variable speed.
- Dual speed (adjustable PCB transfer out speed).
- Hinging topcover.
- Inspect function.
- Alarm buzzer.

Other options available on request.



NTA 410M 1000 • NTA 410XL 1000

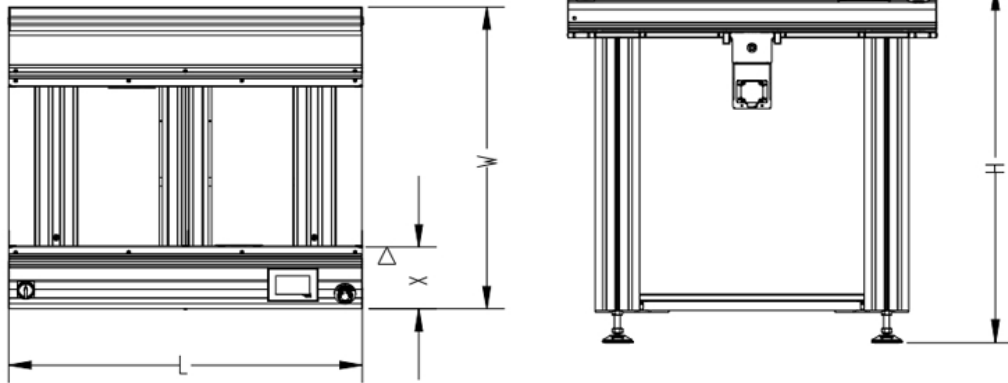

General machine specification

Transfer height:	950 mm ± 25 mm*
Colour:	RAL 9002*
Flow direction:	Left to right*
Fixed rail:	Front*
Machine interface:	IPC-SMEMA-9851*
Components clearance:	Top 30 mm, bottom 30 mm.
Belt speed:	14 m/min
PCB edge support:	3 mm

Installation requirements

Power supply:	230 VAC/50 Hz/1 Ph
Power consumption:	170 VA max

Machine dimensions	NTA 410M 1000	NTA 410XL 1000
Machine dimensions (l x w x h):	1000 x 660 x 980 mm*	1000 x 870 x 980 mm*
Machine weight:	70 kg*	100 kg*
Fixed rail to front dimension (X):	177 mm	177 mm

PCB dimensions	NTA 410M 1000	NTA 410XL 1000
PCB length:	80 - 330 mm	80 - 460 mm*
PCB width:	50 - 250 mm	50 - 460 mm*
PCB thickness:	0,1 - 4 mm*	0,1 - 4 mm*
Max PCB weight:	2,5 kg*	2,5 kg*

* Depending on specification.

NTA 510ICM • NTA 510ICXL

The NTA 510IC series is used in the PCB production line when frequent visual inspection of the PCB's is required. The 4.3" full colour touchscreen display allows easy operation on multiple user levels.

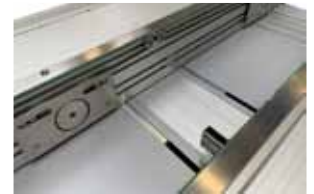

Multi zone concept.



4,3" colour touchscreen display.

Standard features

- Automatic conveyor width adjustment.
- 4,3" full colour touchscreen display.
- Advanced graphic Human Machine Interface (HMI).
- Multi level user acces control.
- In,- & Output diagnostics on touchscreen display.
- 2000 product recipes storage.
- Ethernet connection for network interface.
- Standard conveyor lengths: 500 mm, 1000 mm, 1500 mm.
- Selectable 'Inspect' and 'Bypass' modes.
- Separate PCB release button.
- Dual speed (adjustable PCB transfer out speed).
- Stainless steel PCB side guides.

Options

- IPC-HERMES-9852 communication.
- Automatic product change-over by Nutek leader - follower software.
- Line Control Software ready.
- Remotely accessible PLC.
- Custom made length upon specification.
- Multi zone concept.
- Variable speed.
- Hinging top cover.
- Inspection interval counter.
- Alarm buzzer.

Other options available on request.

NTA 510ICM 1000 • NTA 510ICXL 1000

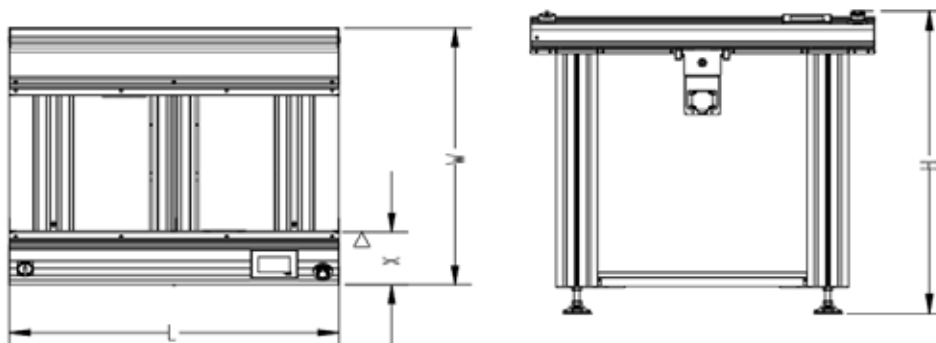

General machine specification

Transfer height:	950 mm ± 25 mm*
Colour:	RAL 9002*
Flow direction:	Left to right*
Fixed rail:	Front*
Machine interface:	IPC-SMEMA-9851*
Components clearance:	Top 30 mm, bottom 30 mm
Belt speed:	Fixed in 14 m/min Variable out 2 - 14 m/min
PCB edge support:	3 mm

Installation requirements

Power supply:	230 VAC/50 Hz/1 Ph
Power consumption:	150 VA max.

Machine dimensions	NTA 510ICM 1000	NTA 510ICXL 1000
Machine dimensions (l x w x h):	1000 x 660 x 980 mm*	1000 x 870 x 980 mm*
Machine weight:	70 kg	100 kg
Fixed rail to front dimension (X):	177 mm	177 mm

PCB dimensions	NTA 510ICM 1000	NTA 510ICXL 1000
PCB length:	80 - 330 mm	80 - 460 mm*
PCB width:	50 - 250 mm	50 - 460 mm*
PCB thickness:	0,1 - 4 mm*	0,1 - 4 mm*
Max PCB weight:	2,5 kg*	2,5 kg*

* Depending on specification.



NTA 51ORCM • NTA 51ORCXL

The NTA 510RC series is used for good/bad PCB separation and verification by operator without interrupting the PCB flow.

A rejected PCB that needs to be checked is lifted 65mm from the ESD belt by metal fingers, allowing good PCB's to pass underneath the lifted PCB.

The 4.3" full colour touchscreen display allows easy operation on multiple user levels.



Reject fingers detail



4,3" colour touchscreen display.

Standard features

- Automatic conveyor width adjustment.
- 4,3" full colour touchscreen display.
- Advanced graphic Human Machine Interface (HMI).
- Multi level user acces control.
- In,- & Output diagnostics on touchscreen display.
- 2000 product recipes storage.
- Ethernet connection for network interface.
- Selectable 'Reject', 'Inspect' and 'Bypass' modes.
- Variable transfer speed.
- Separate PCB release button.
- Stainless steel PCB side guides.

Options

- IPC-HERMES-9852 communication.
- Automatic product change-over by Nutek leader - follower software.
- Line Control Software ready.
- Remotely accessible PLC.
- Custom made length upon specification.
- Multi zone concept.
- Dual speed (adjustable PCB transfer out speed).
- Hinging topcover.
- Overhead lighting.
- Additonal reject position.
- Alarm buzzer.

Other options available on request.



NTA 510RCM 1000 • NTA 510RCXL 1000

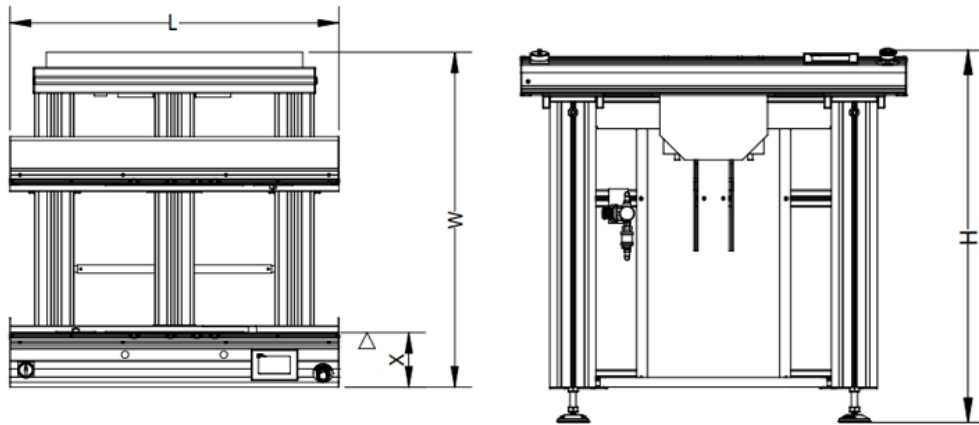

General machine specification

Transfer height:	950 mm ± 25 mm*
Colour:	RAL 9002*
Flow direction:	Left to right*
Fixed rail:	Front*
Machine interface:	IPC-SMEMA-9851*
Components clearance:	Top 30 mm, bottom 30 mm
Belt speed:	2 - 14 m/min
PCB edge support:	3 mm

Installation requirements

Power supply:	230 VAC/50 Hz/1 Ph
Power consumption:	170 VA max
Air supply:	6 bar
Air consumption:	10 ltr/min

Machine dimensions	NTA 510RCM 1000	NTA 510RCXL 1000
Machine dimensions (l x w x h):	1000 x 825 x 980 mm*	1000 x 1030 x 980 mm*
Machine weight:	100 kg	120 kg
Fixed rail to front dimension (X):	165 mm	165 mm

PCB dimensions	NTA 510RCM 1000	NTA 510RCXL 1000
PCB length:	80 - 330 mm	80 - 460 mm*
PCB width:	50 - 250 mm	50 - 460 mm*
PCB thickness:	0,1 - 4 mm*	0,1 - 4 mm*
Max PCB weight:	2,5 kg*	2,5 kg*

* Depending on specification.



NTA 53OWSM • NTA 53OWSXL

The NTA 530WS series is used where manual work in the production line is performed without removing the PCB from the belt segment. The workstation is standard equipped with a work table, overhead lighting, footrest and a sliding part shelf for operator convenience. The 4.3" full colour touchscreen display allows easy operation on multiple user levels.



0-15° angle sliding part shelf.



4,3" colour touchscreen display.

Standard features

- Automatic conveyor width adjustment.
- 4,3" full colour touchscreen display.
- Advanced graphic Human Machine Interface (HMI).
- Multi level user access control.
- In,- & Output diagnostics on touchscreen display.
- 2000 product recipes storage.
- Ethernet connection for network interface.
- Selectable 'Inspect' and 'Bypass' modes.
- Dual speed (adjustable PCB transfer out speed).
- Separate PCB release button.
- ESD work table.
- ESD bracelet connection.
- Foot rest.
- Sliding part shelf (straight)
- LED overhead lighting.
- Stainless steel PCB side guides.

Options

- IPC-HERMES-9852 communication.
- Automatic product change-over by Nutek leader - follower software.
- Line Control Software ready.
- Remotely accessible PLC.
- Custom made length upon specification.
- Multi zone concept.
- Variable speed.
- 0-15° angle sliding part shelf.
- Reject fingers for good/bad PCB separation.
- Alarm buzzer.

Other options available on request.



NTA 530WSM 1000 • NTA 530WSXL 1000

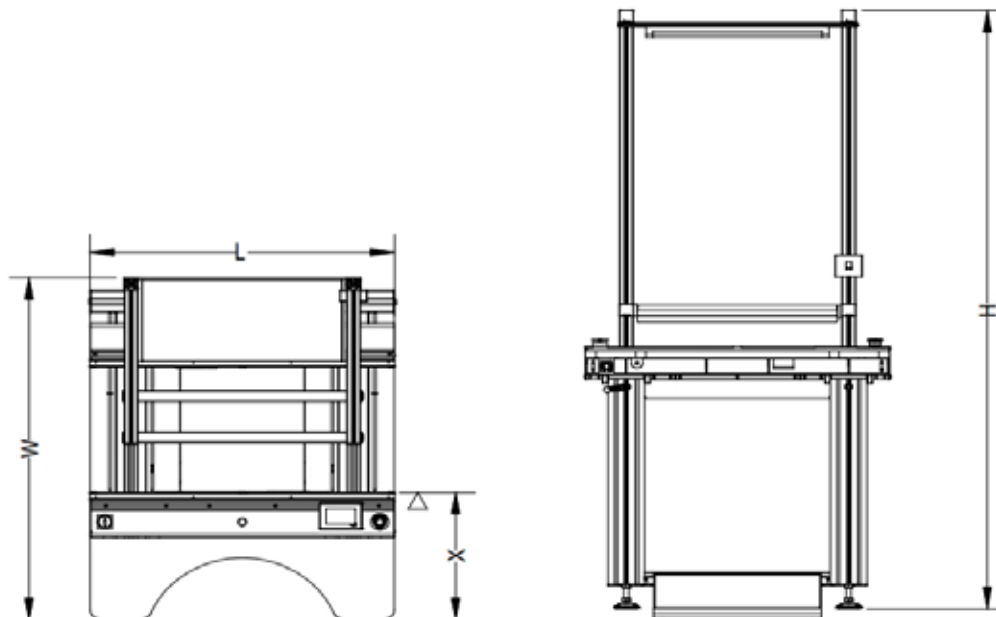

General machine specification

Transfer height:	950 mm ± 25 mm*
Colour:	RAL 9002*
Flow direction:	Left to right*
Fixed rail:	Front*
Machine interface:	IPC-SMEMA-9851*
Components clearance:	Top 30 mm, bottom 30 mm
Belt speed:	Fixed in 14 m/min Variable out 2 - 14 m/min
PCB edge support:	3 mm

Installation requirements

Power supply:	230 VAC/50 Hz/1 Ph
Power consumption:	170 VA max.

Machine dimensions

	NTA 530WSM 1000	NTA 530WSXL 1000
Machine dimensions (l x w x h):	1000 x 1050 x 2190 mm*	1000 x 1250 x 2190 mm*
Machine weight:	130 kg	150 kg
Fixed rail to front dimension (X):	461 mm	461 mm

PCB dimensions

	NTA 510WSM 1000	NTA 530WSXL 1000
PCB length:	80 - 330 mm	80 - 460 mm*
PCB width:	50 - 250 mm	50 - 460 mm*
PCB thickness:	0,1 - 4 mm*	0,1 - 4 mm*
Max PCB weight:	2,5 kg*	2,5 kg*

* Depending on specification.



NTA 45ITGM • NTA 45ITGXL

The NTA 45ITG series is used to create a normally open passage way in a PCB production line. An integrated conveyor segment slides across the opening to deliver the PCB to the downstream machine.

The 7" full colour touchscreen display allows easy operation on multiple user levels.



7" colour touchscreen display.

Standard features

- Automatic conveyor width adjustment.
- 7" full colour touchscreen display.
- Advanced graphic Human Machine Interface (HMI).
- Multi level user access control.
- In,- & Output diagnostics on touchscreen display.
- 2000 product recipes storage.
- Ethernet connection for network interface.
- Fully closed design.
- Swift and smooth retraction/extension by frequency controller.
- Safety retro-reflective sensor for enhanced safety.
- 847 mm open passage way.
- Stainless steel PCB side guides.

Options

- IPC-HERMES-9852 communication.
- Automatic product change-over by Nutek leader - follower software.
- Line Control Software ready.
- Remotely accessible PLC.
- Variable speed.
- Normally closed operation (reduces passage way to 745mm).
- Machine length 2000mm (increase passage way to 1100mm).
- Towerlight display.
- Wireless SMEMA.
- Alarm buzzer.

Other options available on request.



NTA 45ITGM • NTA 45ITGXL

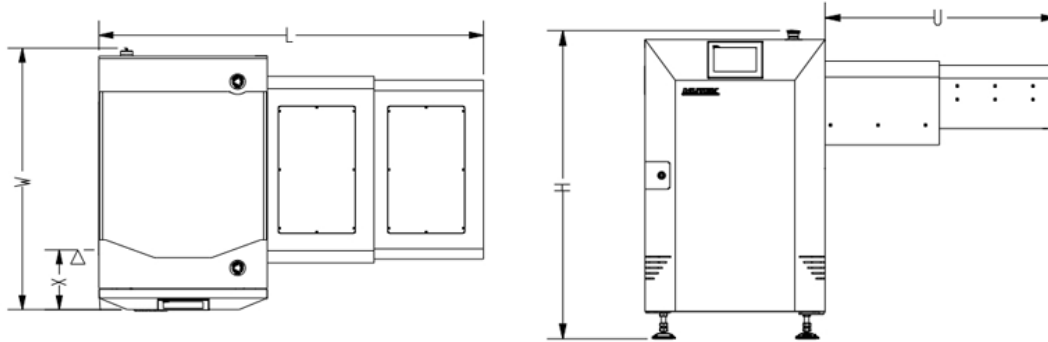

General machine specification

Transfer height:	950 mm ± 25 mm*
Colour:	RAL 9002*
Flow direction:	Left to right*
Fixed rail:	Front*
Machine interface:	IPC-SMEMA-9851*
Components clearance:	Top 30 mm, bottom 30 mm
Belt speed:	14 m/min
Cycle time:	± 15 seconds

Installation requirements

Power supply:	230 VAC/50 Hz/1 Ph
Power consumption:	240 VA max

Machine dimensions

	NTA 451 TGM	NTA 451 TGXL
Machine dimensions (l x w x h):	1500 x 765 x 1130 mm*	1500 x 1030 x 1130 mm*
Machine weight:	230 kg	280 kg
Fixed rail to front dimension (X):	234 mm	234 mm
Passage way (U):	845 mm*	845 mm*

PCB dimensions

	NTA 451 TGM	NTA 451 TGXL
PCB length:	80 - 330 mm	80 - 460 mm*
PCB width:	50 - 250 mm	50 - 460 mm*
PCB thickness:	0,1 - 4 mm*	0,1 - 4 mm*
Max PCB weight:	2,5 kg*	2,5 kg*

* Depending on specification.



NTA 452TGM • NTA 452TGXL

The NTA 452TG series is used to create a normally closed or a normally open passage way in a PCB production line. A timing belt is used to deliver the PCB to the downstream machine and extend/retract the belt guid bars.

The 7" full colour touchscreen display allows easy operation on multiple user levels.



7" colour touchscreen display.

Standard features

- Automatic conveyor width adjustment.
- 7" full colour touchscreen display.
- Advanced graphic Human Machine Interface (HMI).
- Multi level user access control.
- In,- & Output diagnostics on touchscreen display.
- 2000 product recipes storage.
- Ethernet connection for network interface.
- Variable speed.
- Selectable operation mode (normally open or normally closed).
- Passageway of 675 mm.
- Stainless steel PCB side guides.

Options

- IPC-HERMES-9852 communication.
- Automatic product change-over by Nutek leader - follower software.
- Line Control Software ready.
- Remotely accessible PLC.
- Dual speed (adjustable PCB transfer out speed).
- Towerlight display.
- Top cover.
- Alarm buzzer.

Other options available on request.



NTA 452TGM • NTA 452TGXL

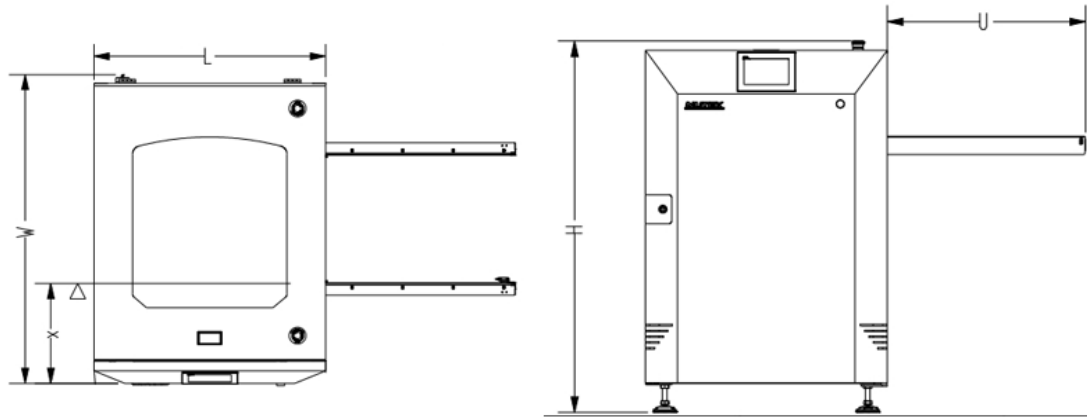

General machine specification

Transfer height:	950 mm ± 25 mm*
Colour:	RAL 9002*
Flow direction:	Left to right*
Fixed rail:	Front*
Machine interface:	IPC-SMEMA-9851*
Components clearance:	Top 30 mm, bottom 30 mm
Belt speed:	Variable 2 - 14 m/min
Cycle time:	± 15 sec normally open operation ± 8 sec normally closed operation

Installation requirements

Power supply:	230 VAC/50 Hz/1 Ph
Power consumption:	300 VA max
Air supply:	6 bar
Air consumption:	2 ltr/min

Machine dimensions

	NTA 452TGM	NTA 452TGXL
Machine dimensions (l x w x h):	825 x 910 x 1285 mm*	825 x 1120 x 1285 mm*
Machine weight:	130 kg	150 kg
Fixed rail to front dimension (X):	360 mm	360 mm
Passage way (U):	675 mm	675 mm

PCB dimensions

	NTA 452TGM	NTA 452TGXL
PCB length:	80 - 330 mm	80 - 460 mm*
PCB width:	50 - 250 mm	50 - 460 mm*
PCB thickness:	0,6 - 4 mm*	0,6 - 4 mm*
Max PCB weight:	2,5 kg*	2,5 kg*

* Depending on specification.

NTA 450MGM 1000 • NTA 450MGXL 1000

The NTA 450MG series is used to create a normally closed passage way in a PCB production line. By manually lifting the conveyor segment a passage way is created to access the other side of the PCB production line.

The 4,3" full colour touchscreen display allows easy operation on multiple user levels.



4,3" colour touchscreen display.

Standard features

- Automatic conveyor width adjustment.
- 4,3" full colour touchscreen display.
- Advanced graphic Human Machine Interface (HMI).
- Multi level user access control.
- In,- & Output diagnostics on touchscreen display.
- 2000 product recipes storage.
- Ethernet connection for network interface.
- Ergonomic air pressure supported opening and closing.
- Locking device to avoid opening during PCB transfer.
- Passage way of 600 mm.
- Stainless steel PCB side guides.

Options

- IPC-HERMES-9852 communication.
- Automatic product change-over by Nutek leader - follower software.
- Line Control Software ready.
- Remotely accessible PLC.
- Variable speed.
- Dual speed (adjustable PCB transfer out speed).
- Buffer mode.
- Inspect function.
- Machine length 1500mm to increase passage way to 900 mm.
- Towerlight display.
- Top cover.
- Alarm buzzer.

Other options available on request.



NTA 450MGM 1000 • NTA 450MGXL 1000

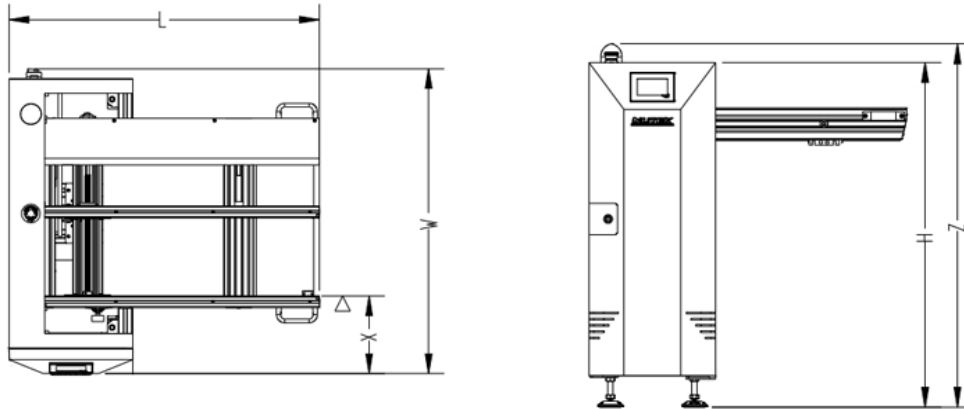

General machine specification

Transfer height:	950 mm ± 25 mm*
Colour:	RAL 9002*
Flow direction:	Left to right*
Fixed rail:	Front*
Machine interface:	IPC-SMEMA-9851*
Components clearance:	Top 30 mm, bottom 30 mm
Belt speed:	14 m/min
PCB edge support:	3 mm

Installation requirements

Power supply:	230 VAC/50 Hz/1 Ph
Power consumption:	170 VA max.
Air supply:	6 bar
Air consumption:	35 ltr/lift

Machine dimensions	NTA 450MGM	NTA 450MGXL
Machine dimensions (l x w x h):	1000 x 945 x 1100 mm*	1000 x 1145 x 1100 mm*
Machine weight:	80 kg	100 kg
Fixed rail to front dimension (X):	250 mm	250 mm
Passage way:	600 mm	600 mm

PCB dimensions	NTA 450MGM	NTA 450MGXL
PCB length:	80 - 330 mm	80 - 460 mm*
PCB width:	50 - 250 mm	50 - 460 mm*
PCB thickness:	0,1 - 4 mm*	0,1 - 4 mm*
Max PCB weight:	2,5 kg*	2,5 kg*

* Depending on specification.



NTA 46ITCM • NTA 46ITCXL

The NTA 461TC series is used to clean the PCB's in line, the machine uses specially formulated elastomer rollers to remove particles from the PCB surface. The contamination is transferred from the elastomer rollers to the easy exchangeable adhesive rolls. The 7" full colour touchscreen display allows easy operation on multiple user levels.



7" colour touchscreen display.

Standard features

- Automatic conveyor width adjustment.
- 7" full colour touchscreen display.
- Advanced graphic Human Machine Interface (HMI).
- Multi level user access control.
- In,- & Output diagnostics on touchscreen display.
- 2000 product recipes storage.
- Ethernet connection for network interface.
- Preset PCB counter and warning for changing sheets of the adhesive rolls.
- Ionizer bar (decharge result may vary).
- Easy access to adhesive rolls.
- Variable speed.
- Alarm buzzer.

Options

- IPC-HERMES-9852 communication.
- Automatic product change-over by Nutek leader - follower software.
- Line Control Software ready.
- Remotely accessible PLC.
- Double sided cleaning (selectable).
- Tower light.

Other options available on request.



NTA 46ITCM • NTA 46ITCXL

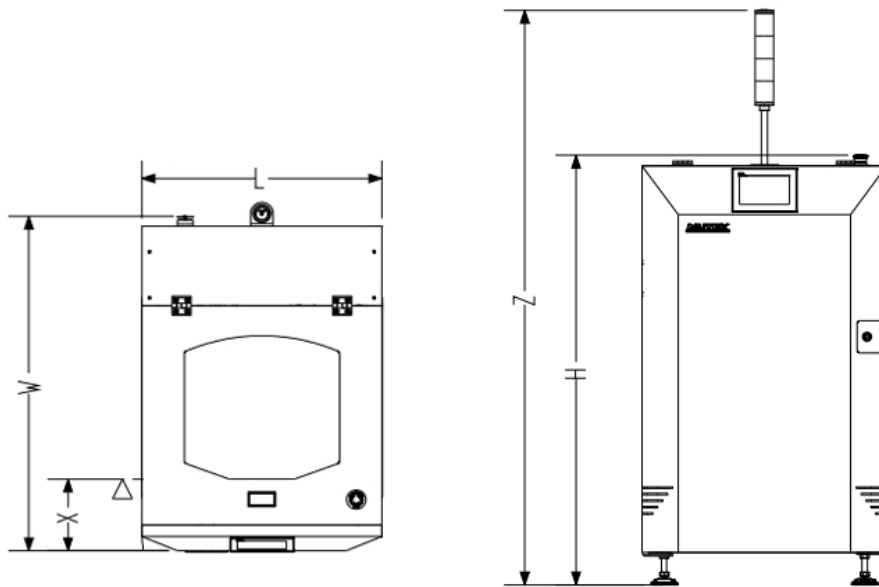

General machine specification

Transfer height:	950 mm ± 25 mm*
Colour:	RAL 9002*
Flow direction:	Left to right*
Fixed rail:	Front*
Machine interface:	IPC-SMEMA-9851*
Components clearance:	Top 30 mm, bottom 30 mm
Belt speed:	Variable 2-14 m/min
PCB edge support:	3 mm

Installation requirements

Power supply:	230 VAC/50 Hz/1 Ph
Power consumption:	260VA max
Air supply:	4-6 bar
Air consumption:	2 ltr/min

Machine dimensions	NTA 461 TCM	NTA 461 TCXL
Machine dimensions (l x w x h):	653 x 800 x 1330 mm*	750 x 1055 x 1330 mm*
Machine weight:	180 kg	200 kg
Fixed rail to front dimension (X):	225 mm	225 mm
Towerlight height (Z):	2000 mm	2000 mm

PCB dimensions	NTA 461 TCM	NTA 461 TCXL
PCB length:	80 - 330 mm	80 - 460 mm*
PCB width:	50 - 250 mm	50 - 460 mm*
PCB thickness:	0,6 - 3 mm*	0,6 - 3 mm*
Max PCB weight:	2,5 kg*	2,5 kg*

* Depending on specification.

NTA 910TVM • NTA 910TVXL

The NTA 910TV series is used to transfer PCB's from one PCB production line into two PCB production lines', 'from single track to dual track operated machines' or vice versa. The integrated shuttle conveyor moves sideways to align with up,- and downstream machines. The 7" full colour touchscreen display allows easy operation on multiple user levels.



7" colour touchscreen display.

Standard features

- Servo driven shuttle conveyor movement.
- Automatic conveyor width adjustment.
- 7" full colour touchscreen display.
- Advanced graphic Human Machine Interface (HMI).
- Multi level user access control.
- In,- & Output diagnostics on touchscreen display.
- 2000 product recipes storage.
- Ethernet connection for network interface.
- Traversing distance and configuration upon request.
- Front and rear adjustable stop positions.

Options

- IPC-HERMES-9852 communication.
- Automatic product change-over by Nutek leader - follower software.
- Line Control Software ready.
- Remotely accessible PLC.
- Customized traversing distance (max 4000 mm)
- Good/bad separation function.
- Safety shutter at in,- and outlet.
- Cantilevered input or output conveyor (500 mm)
- Towerlight.
- Alarm buzzer.

Other options available on request.



NTA 910TVM • NTA 910TVXL

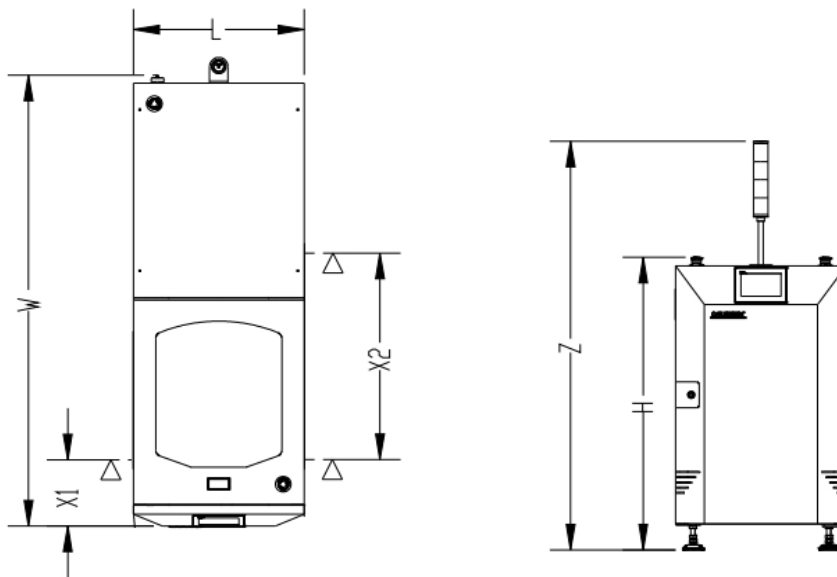

General machine specification

Transfer height:	950 mm ± 25 mm*
Colour:	RAL 9002*
Flow direction:	Left to right*
Fixed rail:	Front*
Machine interface:	IPC-SMEMA-9851*
Components clearance:	Top 30 mm, bottom 30 mm
Belt speed:	Fixed 14 m/min
Machine cycle time:	Depending on traversing distance*

Installation requirements

Power supply:	230 VAC/50 Hz/1 Ph
Power consumption:	340 VA max.

Machine dimensions

	NTA 910TVM	NTA 910TVXL
Machine dimensions (l x w x h):	500 x 1750 x 1130 mm*	653 x 1750 x 1130 mm*
Machine weight:	180 kg	240 kg
Fixed rail to front dimension (X1):	256 mm	256 mm
Fixed to Fixed distance (X2):	800 mm*	800 mm*
Towerlight height (Z):	2000 mm	2000 mm

PCB dimensions

	NTA 910TVM	NTA 910TVXL
PCB length:	80 - 330 mm	80 - 460 mm*
PCB width:	50 - 250 mm	50 - 460 mm*
PCB thickness:	0,4 - 4 mm*	0,4 - 4 mm*
Max PCB weight:	2,5 kg*	2,5 kg*

* Depending on specification.



NTA 310IM • NTA 310IXL

The NTA 310I series is used to invert/flip PCB's 180° for double sided production, the flip is done over the Y-axis of the PCB. PCB leading edge will become PCB trailing edge.

The 7" full colour touchscreen display allows easy operation on multiple user levels.



7" colour touchscreen display.

Standard features

- Automatic conveyor width adjustment.
- 7" full colour touchscreen display.
- Advanced graphic Human Machine Interface (HMI).
- Multi level user access control.
- In,- & Output diagnostics on touchscreen display.
- 2000 product recipes storage.
- Ethernet connection for network interface.
- Built-in torque limiter.
- Inversions continue from last unloading, cycle time decrease.

Options

- IPC-HERMES-9852 communication.
- Automatic product change-over by Nutek leader - follower software.
- Line Control Software ready.
- Remotely accessible PLC.
- Cantilevered input or output conveyor.
- Top clamping to hold down PCB during inverting.
- Safety shutter at in,- or outlet.
- Towerlight.
- Alarm buzzer.

Other options available on request.



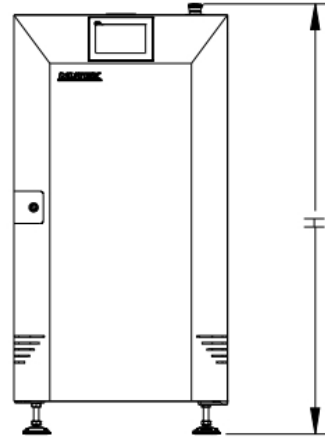
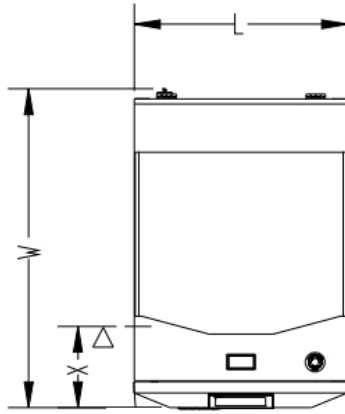

General machine specification

Transfer height:	950 mm ± 25 mm*
Colour:	RAL 9002*
Flow direction:	Left to right*
Fixed rail:	Front*
Machine interface:	IPC-SMEMA-9851*
Components clearance:	Top 30 mm, bottom 30 mm
Belt speed:	Fixed 14 m/min
Machine cycle time:	±8 seconds

Installation requirements

Power supply:	230 VAC/50 Hz/1 Ph
Power consumption:	240 VA max
Air supply:	6 bar
Air consumption:	2 ltr/min

Machine dimensions

	NTA 310IM	NTA 310IXL
Machine dimensions (l x w x h):	500 x 815 x 1330 mm	653 x 985 x 1330 mm*
Machine weight:	110 kg	130 kg
Fixed rail to front dimension (X):	256 mm	256 mm

PCB dimensions

	NTA 310IM	NTA 310IXL
PCB length:	80 - 330 mm	80 - 460 mm*
PCB width:	50 - 250 mm	50 - 460 mm*
PCB thickness:	0,6 - 4 mm*	0,6 - 4 mm*
Max PCB weight:	2,5 kg*	2,5 kg*

* Depending on specification.

NTA 34OLM • NTA 34OLXL

The NTA 340L series is used in production lines with a PCB/pallet return conveyor system. The lift brings PCB/pallet from the upper to the lower conveyor level or vice versa.

The 7" full colour touchscreen display allows easy operation on multiple user levels.



7" colour touchscreen display.

Standard features

- Automatic conveyor width adjustment.
- 7" full colour touchscreen display.
- Advanced graphic Human Machine Interface (HMI).
- Multi level user access control.
- In,- & Output diagnostics on touchscreen display.
- 2000 product recipes storage.
- Ethernet connection for network interface.
- Frequency inverter controlled lifting motion.
- Ball screw driven lift movement.
- Machine configuration upon request.

Options

- IPC-HERMES-9852 communication.
- Automatic product change-over by Nutek leader - follower software.
- Line Control Software ready.
- Remotely accessible PLC.
- Servo driven lifter for shortened cycle time.
- Tall version for 'overhead' solutions.
- Built according to specification.
- Cantilevered input- or output conveyor (500mm).
- Good/bad separation function.
- Safety shutter at in,- or outlet.
- Pneumatic stopper at inlet to control product flow from upstream.
- Towerlight.
- Alarm buzzer.

Other options available on request.



NTA 340LM • NTA 340LXL

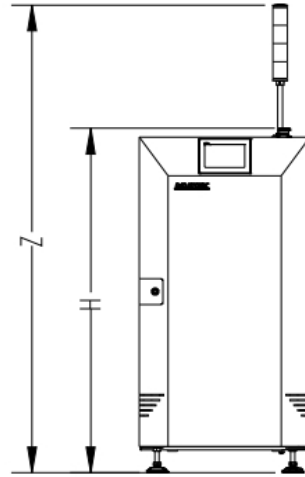
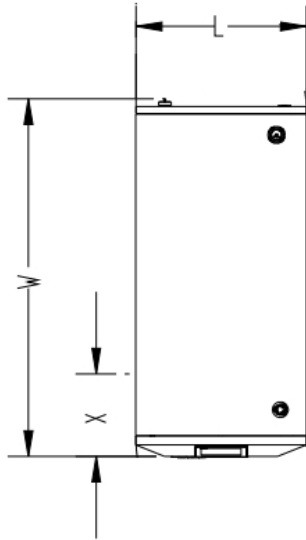

General machine specification

Transfer height:	950 mm ± 25 mm*
Colour:	RAL 9002*
Flow direction:	Left to right*
Fixed rail:	Front*
Machine interface:	IPC-SMEMA-9851*
Components clearance:	Top 30 mm, bottom 30 mm
Belt speed:	Fixed 14 m/min
Machine cycle time:	±25 seconds*

Installation requirements

Power supply:	230 VAC/50 Hz/1 Ph
Power consumption:	350 VA max

Machine dimensions

	NTA 340LM	NTA 340LXL
Machine dimensions (l x w x h):	500 x 1175 x 1330 mm*	653 x 1385 x 1330 mm*
Machine weight:	160 kg	200 kg
Fixed rail to front dimension (X):	320 mm	320 mm

PCB dimensions

	NTA 340LM	NTA 340LXL
PCB length:	80 - 330 mm	80 - 460 mm*
PCB width:	50 - 250 mm	50 - 460 mm*
PCB thickness:	0,4 - 4 mm*	0,4 - 4 mm*
Max PCB weight:	2,5 kg*	2,5 kg*

* Depending on specification.

NTA 9I • NTA 18I • NTA 27I • NTA 36I

The NTA turn conveyor series is designed to change the flow direction of a PCB production line. The PCB is transferred onto the built-in conveyor which turns clockwise and/or counter clockwise.

The 7" full colour touchscreen display allows easy operation on multiple user levels.



7" colour touchscreen display.

Standard features

- Automatic conveyor width adjustment.
- 7" full colour touchscreen display.
- Advanced graphic Human Machine Interface (HMI).
- Multi level user access control.
- In,- & Output diagnostics on touchscreen display.
- 2000 product recipes storage.
- Ethernet connection for network interface.
- NTA 9I turning 90° clockwise or counter clockwise.
- NTA 18I turning 180° to change fixed rail position.
- NTA 27I, NTA 36I various configurations possible (upon specification).
- By pass mode.
- Lateral transfer system to reduce gap with up,- and downstream machine.
- Machine configuration upon request.

Options

- IPC-HERMES-9852 communication.
- Automatic product change-over by Nutek leader - follower software.
- Line Control Software ready.
- Remotely accessible PLC.
- Servo drive upgrade for shortened cycle time.
- Built according to specification.
- Cantilevered input- or output conveyor.
- Good/bad separation function.
- Safety shutter at in- and outlet.
- Towerlight.
- Alarm buzzer.

Other options available on request.



NTA 91 • NTA 181 • NTA 271 • NTA 361

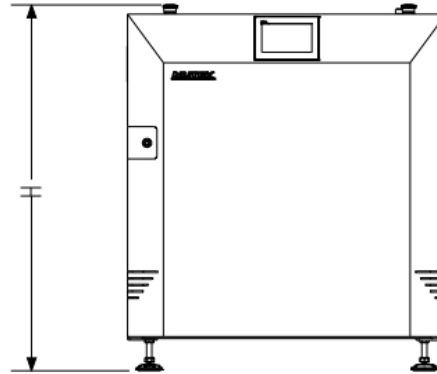
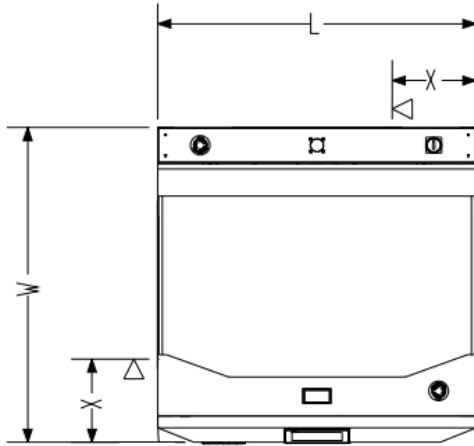

General machine specification

Transfer height:	950 mm ± 25 mm*
Colour:	RAL 9002*
Flow direction:	Left to right*
Fixed rail:	Front*
Machine interface:	IPC-SMEMA-9851*
Components clearance:	Top 30 mm, bottom 30 mm
Belt speed:	Fixed 14 m/min
Machine cycle time:	±16 seconds*

Installation requirements

Power supply:	230 VAC/50 Hz/1 Ph
Power consumption:	270 VA max
Air supply:	6 bar
Air consumption:	1,5 ltr/min

Machine dimensions	NTA 91,181,271,361 M	NTA 91,181,271,361 XL
Machine dimensions (l x w x h):	795 x 795 x 1130 mm	975 x 975 x 1130 mm*
Machine weight:	160 kg	200 kg
Fixed rail to front dimension (X):	272,5 mm	257,5 mm

PCB dimensions	NTA 91,181,271,361 M	NTA 91,181,271,361 XL
PCB length :	80 - 330 mm	80 - 460 mm*
PCB width :	50 - 250 mm	50 - 460 mm*
PCB thickness :	0,4 - 4 mm*	0,4 - 4 mm*
Max PCB weight:	2,5 kg*	2,5 kg*

* Depending on specification.



NTA 610SM • NTA 610SXL

The NTA 610S is a single magazine buffer with a servo driven magazine lifter platform with a single magazine capacity. The dual function pneumatic pusher assembly is used to push the PCB in or out of the magazine. This buffer can be used as a mid-line loader/unloader, as a LIFO/FIFO buffer or as an reject buffer. The 7" full colour touchscreen display allows easy operation on multiple user levels.



7" colour touchscreen display.

Standard features

- Servo driven lifter platform.
- Automatic conveyor width adjustment.
- 7" full colour touchscreen display.
- Advanced graphic Human Machine Interface (HMI).
- Multi level user access control.
- In,- & Output diagnostics on touchscreen display.
- 2000 product recipes storage.
- Ethernet connection for network interface.
- 5 operation modes.
 - Buffer mode (LIFO/FIFO).
 - Load mode.
 - Unload mode.
 - Reject mode.
 - Bypass mode (Push PCB through magazine).
- Oven info threshold signal.
- Programmable outfeed delay timer.
- Regulated pressure on the pusher cylinders.
- Manual adjustable pusher position.
- Towerlight display for machine status.

Options

- IPC-HERMES-9852 communication.
- Automatic product change-over by Nutek leader - follower software.
- Line Control Software ready.
- Remotely accessible PLC.
- Safety shutter at in,- and/or outlet.
- Front side magazine exchange.
- By-pass conveyor above magazine platform.
- Two magazine lengths option (incl. rotary idler).
- Width adjustable magazine conveyor to handle other magazine length.
- Cooling fans.
- Alarm buzzer.

Other options available on request.

NTA 610SM • NTA 610SXL

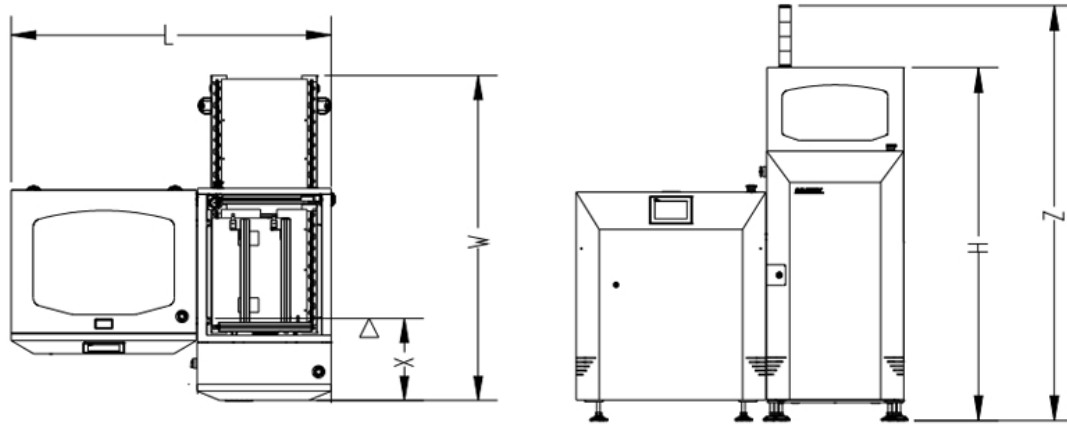

General machine specification

Transfer height:	950 mm ± 25 mm*
Colour:	RAL 9002*
Flow direction:	Left to right*
Fixed rail:	Front*
Machine interface:	IPC-SMEMA-9851*
Components clearance:	Top 30 mm, bottom 30 mm
Machine cycle time:	± 19 seconds (board to board)
Pitch control:	Flexible pitch settings.
Maximum magazine weight:	50 kg.

Installation requirements

Power supply:	230 VAC/50 Hz/1 Ph
Power consumption:	530 VA max
Air supply:	6 bar
Air consumption:	27 ltr/min max

Machine dimensions	NTA 610SM	NTA 610SXL
Machine dimensions (l x w x h):	1260 x 1190 x 1700 mm	1560 x 1610 x 1700 mm
Machine weight:	200 kg	300 kg
Fixed rail to front dimension (X):	405 mm	405 mm
Towerlight height (Z):	2000 mm	2000 mm

PCB dimensions	NTA 610SM	NTA 610SXL
PCB length:	80 - 330 mm	80 - 460 mm*
PCB width:	50 - 250 mm	50 - 460 mm*
PCB thickness:	0,4 - 2,6 mm*	0,4 - 2,6 mm*
PCB weight:	2,5 kg*	2,5 kg*
Magazine dimensions (max.):	355 x 320 x 570 mm	535 x 530 x 570 mm

* Depending on specification.

NTA 620SM • NTA 620SXL

The NTA 620S is a multi magazine buffer with a 5 magazine capacity, 2 empty magazines on the upper magazine conveyor, 2 full magazines on the lower magazine conveyor and 1 magazine is on the servo driven lifter. The dual function pneumatic pusher assembly is used to push the PCB in or out of the magazine. This buffer can be used as a high capacity mid-line loader/unloader, as a LIFO/FIFO buffer or as a reject buffer. The 7" full colour touchscreen display allows easy operation on multiple user levels.



7" colour touchscreen display.

Standard features

- Servo driven lifter platform.
- Automatic conveyor width adjustment.
- 7" full colour touchscreen display.
- Advanced graphic Human Machine Interface (HMI).
- Multi level user access control.
- In,- & Output diagnostics on touchscreen display.
- 2000 product recipes storage.
- Ethernet connection for network interface.
- 5 operation modes.
 - Buffer mode (LIFO/FIFO).
 - Load mode.
 - Unload mode.
 - Reject mode.
 - Bypass mode (Push PCB through magazine).
- Oven info threshold signal.
- Programmable outfeed delay timer.
- Regulated pressure on the pusher cylinders.
- Manual adjustable pusher position.
- Towerlight display for machine status.

Options

- IPC-HERMES-9852 communication.
- Automatic product change-over by Nutek leader - follower software.
- Line Control Software ready.
- Remotely accessible PLC.
- Safety shutter at in,- and/or outlet.
- Front side magazine exchange.
- By-pass conveyor above magazine platform.
- Two magazine lengths option (incl. rotary idler).
- Width adjustable magazine conveyor to handle other magazine length.
- Cooling fans.
- Alarm buzzer.

Other options available on request.

NTA 620SM • NTA 620SXL

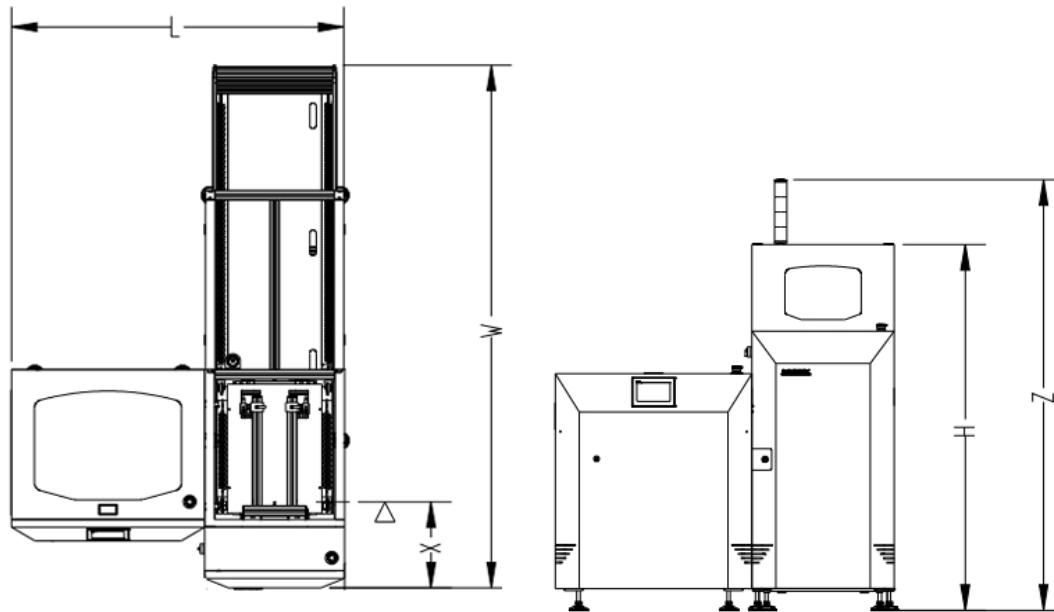

General machine specification

Transfer height:	950 mm ± 25 mm*
Colour:	RAL 9002*
Flow direction:	Left to right*
Fixed rail:	Front*
Machine interface:	IPC-SMEMA-9851*
Components clearance:	Top 30 mm, bottom 30 mm
Machine cycle time:	± 19 seconds (board to board)
Magazine change over time:	± 22 seconds
Pitch control:	Flexible pitch settings
Maximum magazine weight:	50 kg.

Installation requirements

Power supply:	230 VAC/50 Hz/1 Ph
Power consumption:	740 VA max
Air supply:	6 bar
Air consumption:	27 ltr/min max

Machine dimensions

	NTA 620SM	NTA 620SXL
Machine dimensions (l x w x h):	1260 x 1775 x 1700 mm	1560 x 2470 x 1700 mm
Machine weight:	230 kg	330 kg
Fixed rail to front dimension (X):	405 mm	405 mm
Towerlight height (Z):	2000 mm	2000mm

PCB dimensions

	NTA 620SM	NTA 620SXL
PCB length:	80 - 330 mm	80 - 460 mm*
PCB width:	50 - 250 mm	50 - 460 mm*
PCB thickness:	0,4 - 2,6 mm*	0,4 - 2,6 mm*
PCB weight:	2,5 kg*	2,5 kg*
Magazine dimensions (max):	355 x 320 x 570 mm	535 x 530 x 570 mm

* Depending on specification



NTA 640SM • NTA 640SXL

The NTA 640S FIFO buffer is designed to buffer PCB's in FIFO mode. The PCB's are transferred by special ESD rollers onto the pick-up location. Metal support bars lift the PCB carefully from the conveyor segment and stores them untill downstream request. The 7" full colour touchscreen display allows easy operation on multiple user levels.



Support bars.



7" colour touchscreen display.

Standard features

- Servo driven lifter.
- Automatic conveyor width adjustment.
- 7" full colour touchscreen display.
- Advanced graphic Human Machine Interface (HMI).
- Multi level user acces control.
- In,- & Output diagnostics on touchscreen display.
- 2000 product recipes storage.
- Ethernet connection for network interface.
- 3 operation modes.
 - Buffer mode (LIFO/FIFO).
 - Bypass mode.
- Oven info treshold signal.
- Programmable outfeed delay timer.
- Flexible repositioning of support bars.
- Durable rollers as conveying medium.
- Ethernet communication for network interface.
- Towerlight display for machine status.

Options

- IPC-HERMES-9852 communication.
- Automatic product change-over by Nutek leader - follower software.
- Line Control Software ready.
- Remotely accessible PLC.
- Safety shutter at in,- and/or outlet.
- Reject mode for buffering bad boards.
- Cooling fans.
- Cantilevered input or output conveyor (500 mm).
- Intelligent treshold counter to stop PCB infeed into reflow oven.
- Alarm buzzer.

Other options available on request.



NTA 640SM • NTA 640SXL

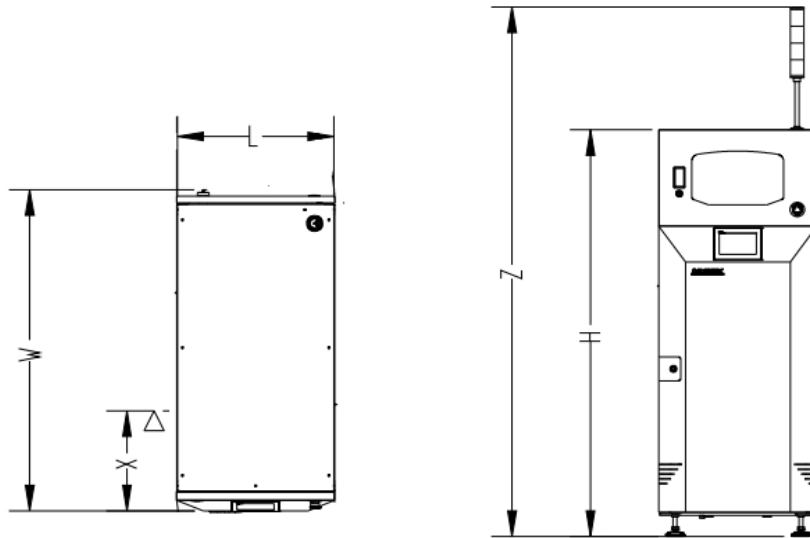

General machine specification

Transfer height:	950 mm ± 25 mm*
Colour:	RAL 9002*
Flow direction:	Left to right*
Fixed rail:	Front*
Machine interface:	IPC-SMEMA-9851*
Components clearance:	Top 30 mm, bottom 30 mm
Machine cycle time:	10 - 25 seconds*
Buffer capacity:	26 PCB's at pitch 1
Pitch control:	Flexible pitch settings
Pitch:	20 mm
Product height:	Selected pitch setting -5 mm

Installation requirements

Power supply:	230 VAC/50 Hz/1 Ph
Power consumption:	730 VA max
Air supply:	6 bar
Air consumption:	2 ltr/min max

Machine dimensions	NTA 640SM	NTA 640SXL
Machine dimensions (l x w x h):	500 x 1190 x 1700 mm	653 x 1350 x 1700 mm
Machine weight:	210 kg	260 kg
Fixed rail to front dimension (X):	450 mm	450 mm
Towerlight height (Z):	2000 mm	2000 mm

PCB dimensions	NTA 640SM	NTA 640SXL
PCB length:	80 - 330 mm	80 - 460 mm*
PCB width:	50 - 250 mm	50 - 460 mm*
PCB thickness:	0,4 - 2,6 mm*	0,4 - 2,6 mm*
PCB weight:	2,5 kg*	2,5 kg*

* Depending on specification.

NTA 660SM • NTA 660SXL

The NTA 660S Belt FIFO buffer allows buffering of PCB's in FIFO or LIFO mode, the buffer uses individual belt segments which support each PCB over its full length. When a PCB is buffered or released a drive mechanism engages with the belt segment to smoothly transfer the PCB. The 7" full colour touchscreen display allows easy operation on multiple user levels.



Belt segments.



7" colour touchscreen display.

Standard features

- Servo driven lifter.
- Automatic conveyor width adjustment.
- 7" full colour touchscreen display.
- Advanced graphic Human Machine Interface (HMI).
- Multi level user access control.
- In,- & Output diagnostics on touchscreen display.
- 2000 product recipes storage.
- Ethernet connection for network interface.
- Buffer capacity of 20 PCB's at 27mm pitch.
- 3 operation modes.
 - Buffer mode (LIFO/FIFO).
 - Bypass mode.
- Oven info threshold signal.
- Programmable outfeed delay timer.
- Ethernet communication for network interface.
- Towerlight display for machine status.

Options

- IPC-HERMES-9852 communication.
- Automatic product change-over by Nutek leader - follower software.
- Line Control Software ready.
- Remotely accessible PLC.
- Safety shutter at in,- and/or outlet.
- Different belt concept for product weight > 2 kg.
- Reject mode for buffering bad boards.
- Cooling fans.
- Cantilevered input or output conveyor (500 mm).
- Intelligent threshold counter to stop PCB infeed into reflow oven.
- Buffer capacity of 12 PCB's at 27 mm pitch.
- Buffer capacity of 30 PCB's at 24 mm pitch.
- Alarm buzzer.

Other options available on request.

NTA 660SM • NTA 660SXL

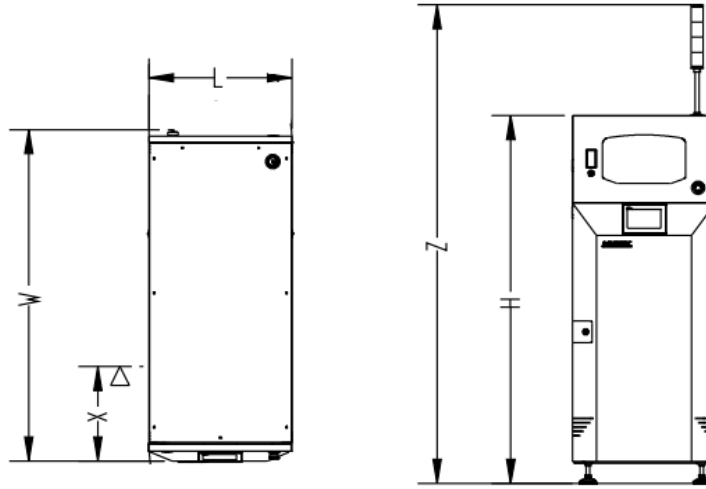

General machine specification

Transfer height:	950 mm ± 25 mm*
Colour:	RAL 9002*
Flow direction:	Left to right*
Fixed rail:	Front*
Machine interface:	IPC-SMEMA-9851*
Components clearance:	Top 30 mm, bottom 30 mm
Machine cycle time:	10 - 23 seconds*
Buffer capacity:	20 PCB's at pitch 1
Pitch control:	Flexible pitch settings
Pitch:	27 mm

Installation requirements

Power supply:	230 VAC/50 Hz/1 Ph
Power consumption:	730 VA max
Air supply:	6 bar
Air consumption:	2 ltr/min max

Machine dimensions	NTA 660SM	NTA 660SXL
Machine dimensions (l x w x h):	500 x 1275 x 1700 mm	653 x 1535 x 1700 mm
Machine weight:	210 kg	260 kg
Fixed rail to front dimension (X):	435 mm	435 mm
Towerlight height (Z):	2000 mm	2000 mm

PCB dimensions	NTA 660SM	NTA 660SXL
PCB length:	80 - 330 mm	80 - 460 mm*
PCB width:	50 - 250 mm	50 - 460 mm*
PCB thickness:	0,4 - 2,6 mm*	0,4 - 2,6 mm*
PCB weight:	2 kg*	2 kg*

* Depending on specification.

Europe

Bliek 23
 4941 SG Raamsdonksveer
 The Netherlands
 T: (31) 162 578 578
 F: (31) 162 578 579
 E: info@nutek-europe.com
 W: <http://www.nutek-europe.com>

United Kingdom

Lodge Park
 Lodge lane, Langham
 Colchester, Essex CO4 5NE
 United Kingdom
 T: (44) 1206 233 538
 F: (44) 1206 233 539
 E: info@nutek-uk.com
 W: <http://www.nutek-uk.com>

Australia

75-77, Westgate drive
 Alton North, Victoria 3025
 Australia
 T: (61) 3 8369 6600
 F: (61) 3 8368 2699
 E: gcp@hrltd.com.au

Asia (main design & manufacturing centre)

39, Joo Koon Circle
 Singapore 629105
 T: (65) 6862 0255
 F: (65) 68620040
 E: info@nutek-sg.com
 W: <http://www.nutek-sg.com>

China

Room 1016, Huaihai China Tower
 885, Ren Min Road
 Shanghai 200010, China
 T: (86) 21 6355 3926/27
 F: (86) 21 6355 3933
 E: info@nutek-china.com

Americas

1831, Lefthand circle, Suite A
 Longmont, Colorado 80501
 United States of America
 T: (1) 303 684 0400
 F: (1) 303 684 9886
 E: info@nutekamericas.com
 W: <http://www.nutekamericas.com>